

## SUPERAUTOMATIC TYRE CHANGER FOR CAR, RACING AND VAN WHEELS



11÷25" in diameter  
and 14" wide

Tilting  
column

WING  
tool head

Intensive  
use

**Aquila AS 943** is solid and sturdy, it is especially suitable for intensive use. The high quality of the components used and severe tests implemented make this machine extremely reliable and minimise maintenance costs. The AS 943 is available upon request with two rotation speeds

(6.5 - 15rpm).

It can also be equipped with the **Super RM device**, as shown on the following page, or other HELPERS as well as the approved kit for **mounting and demounting Michelin, Pirelli, Goodyear e Dunlop Pax System wheels.**

## GENERAL FEATURES

### TOOL HEAD

The **new (patented) steel WING tool head**, with its innovative design, improves tyre changer performance, making tyre demounting and mounting operations significantly easier.

The rear wing helps to **channel the bead** during mounting and the **redesigned** lever support area helps the bead to remain in position during demounting. Definitely useful on Runflat and UHP tyres. Plastic protections avoid accidental scratching of the rims.

Drop-down sliding tool and automatic clamping with increased cross-section (60mm x 60mm) for greater torsional rigidity when force is applied.

The column has a broached head with roller for a smoother horizontal shaft stroke, and is adjustable to maintain performance over time.



### BEAD BREAKER

The bead breaker arm allows an opening **up to 410 mm**, and is fitted with a stroke regulator to eliminate the risk of crushing the tyre.

The bead breaker is operated by a double-acting pneumatic cylinder made from 100% stainless steel, generating a power of **15500 N** on the blade.

Another important innovation is the introduction of a **double adjustment for the inclination of the bead breaking blade**. This adjustment acts in two different directions: up-down and inside-outside.

Thanks to these adjustments, the bead breaking arm will always be in the best possible position.



# RECOMMENDED ACCESSORIES



**A. 8-11100292 SL80 A**  
Wheel lifter

**B. 8-11120097 SUPER RM New**  
Power unit multi-function

**C. 8-11100181 Kit RM2**  
Mobile bead pressure device

**D. 8-11100183 Kit RM3**  
Bead lifter

**E. 8-11100343 SRM 300 + 8-1110346**  
**KIT CUSTOMIZE**

It is practical and functional Helper device specifically designed to make mounting and demounting operations quicker, more precise and safer.

For more information, please consult the accessories catalogue.

## TECHNICAL DATA

## EQUIPMENT

### Turntable

Inside clamping capacity	13" ÷ 25"
Outside clamping capacity	11" ÷ 22"
Maximum tyre diameter	1040 mm (41")
Maximum tyre width	14"
Rotation torque	1200 Nm (400v 3ph)
Rotation speed	8,5 rpm / 6-15 rpm (2V)

### Bead breaker

Maximum opening	410 mm
Shoe force	15.500 N - 10bar

### Power supply

Electric motor three-phase	230-400V 50/60Hz 0,75kW
Electric motor single-phase 2V	230V 50/60Hz 0,75kW
Electric motor single-phase	115-230V 50/60Hz 0,75kW



The company reserves the right to modify the technical specifications of its products at any time.

## DIMENSIONS

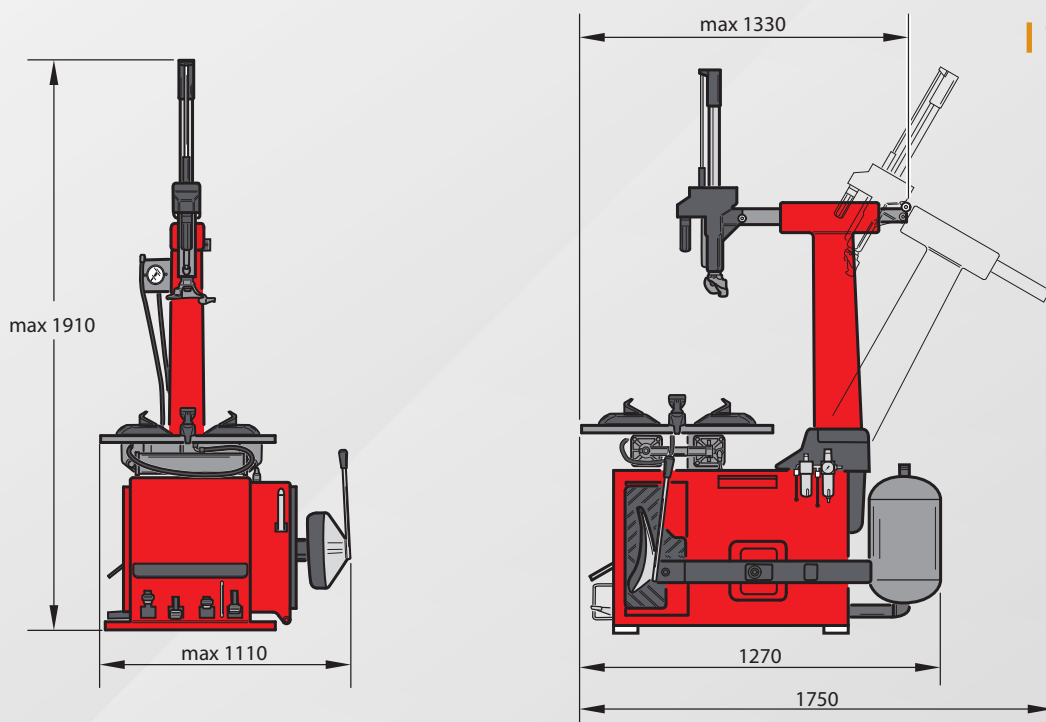

**WEIGHT: 274 kg**