



BY  
AHCON®

# PARTNER LINE

WHEEL LIFTS  
WHEEL TROLLEY LIFT  
WHEEL TROLLEY

---

LIFTING ROLLER TABLES  
CENTERING LIFT  
BEAD BREAKERS

---

INFLATION STATIONS  
ROLLER TABLES  
TYRE SEAT OPTIMIZING

---

POWER WALLS  
SAFETY INFLATION CAGES  
COMPUTER INFLATORS

---

TYRE SPREADER

---

To be ordered with Mondolfo Ferro customization kit 8-51120010



# WHEEL LIFTS - FULLY AUTOMATIC

## WHEEL LIFTS - FULLY AUTOMATIC

The fully automatic wheel lifts is one of the first steps towards an optimised cycle when working with wheels. With a wheel lift the fitter avoids having to bend down and perform heavy lifting from the floor in order to get the wheels up to the same height as, among other things, the bead breaker and tyre changer. The fully automatic wheel lift is available with a place for 1 wheel, or in a version, which can be built together with a supply table, with a place for 3 wheels. The wheel is rolled onto the small plate at the front of the lift, after which it is lifted automatically.

## RADHEBER - VOLLAUTOMATISCH

Die vollautomatische Radheber sind einer der ersten Schritte eines optimierten Arbeitsablaufs mit Rädern. Ein Radheber verhindert, dass sich der Monteur herabbeugen und einen schweren Hubvorgang vom Boden ausüben muss, um die Räder auf die Höhe von Reifenabdrücker und Reifenmontiermaschine zu bekommen. Der vollautomatische Radheber ist mit Platz für ein Rad oder in einer Variante erhältlich, die sich zusammen mit einem Ablegungstisch mit Platz für drei Räder aufbauen lässt. Das Rad wird über die kleine Platte vorn am Radheber gerollt, wonach es automatisch angehoben wird.

## SOLLEVATORI RUOTE COMPLETAMENTE AUTOMATICI

I sollevatori ruote completamente automatici rappresentano uno dei primi passi verso l'ottimizzazione del ciclo di lavoro con le ruote. Grazie all'aiuto del sollevatore ruote il montatore non deve più piegarsi e sollevare pesi gravosi dal pavimento per portare le ruote alla stessa altezza ad esempio dello stallonatore e dello smontagomme. Il sollevatore ruote completamente automatico è disponibile con alloggiamento per 1 ruota o in alternativa in una versione, che può essere costruita congiuntamente ad una tavola di alimentazione, con l'alloggiamento per 3 ruote. La ruota viene fatta rotolare sulla piccola piastra posizionata nella parte anteriore del sollevatore, per poi essere sollevata automaticamente.





## WHEEL LIFT WL 900

Fully automatic wheel lift incl. support table for one wheel.  
The lifting function is triggered automatically when the wheel touches the plate in front.

### COLOURS

7016



9006

## RADHEBER WL 900

Vollautomatischer Radheber einschl. Ablegungstisch für ein Rad.  
Die Hebefunktion wird automatisch ausgelöst, sobald das Rad die vordere Platte berührt.

### VEHICLE



## SOLLEVATORE RUOTE WL 900

Sollevatore ruote completamente automatico con tavola di supporto per una ruota  
La funzione di sollevamento viene attivata automaticamente quando la ruota tocca la piastra anteriore.

### MAX LOAD



MODEL	ITEM NO.	DIMENSIONS (H) X (W) X (L)
WL 900	0-51101901/00	700 MM (H) X 660 MM (W) X 400 MM (L) / 27.5" (H) X 26" (W) X 15.7" (L)



## WHEEL LIFT WL 900+

Fully automatic wheel lift incl. support table for 3 wheels.  
The lifting function is triggered automatically when the wheel touches the plate in front.

### COLOURS

7016



9006

## RADHEBER WL 900+

Vollautomatischer Radheber einschl. Ablegungstisch für 3 Räder.  
Die Hebefunktion wird automatisch ausgelöst, sobald das Rad die vordere Platte berührt.

### VEHICLE



## SOLLEVATORE RUOTE WL 900+

Sollevatore ruote completamente automatico con tavola di supporto per 3 ruote. La funzione di sollevamento viene attivata automaticamente quando la ruota tocca la piastra anteriore.

### MAX LOAD



MODEL	ITEM NO.	DIMENSIONS (H) X (W) X (L)
WL 900+	0-51102001/00	700 MM (H) X 660 MM (W) X 2.200 MM (L) / 27.5" (H) X 26" (W) X 86.6" (L)

# WHEEL TROLLEY LIFT - SEMI AUTOMATIC

## WHEEL TROLLEY LIFT - SEMI AUTOMATIC

We have developed a semi automatic lift, which – on an equal footing with fully automatic wheel lifts – are used for bringing wheels up to the same height as the bead breaker or tyre changer. The Wheel Trolley lift, lifts 1-4 wheels horizontally on a Wheel Trolley.

### COMPATIBLE WITH WHEEL TROLLEYS

The Wheel Trolley lift has a specially designed lifting device, which fits in under the Wheel Trolley, whereby the trolley and the wheels are lifted together.

## WHEEL TROLLEY HEBER - HALBAUTOMATISCH

Wir haben eine halbautomatische Radheber entwickelt, die – ebenso wie die vollautomatischen Radheber – zum Anheben von Rädern auf die Höhe von Reifenabdrücker oder Reifenmontiermaschine verwendet werden. Der Wheel Trolley Heber, hebt 1-4 Räder waagrecht angeordnet auf einen Wheel Trolley.

### KOMPATIBEL MIT WHEEL TROLLEYS

Der Wheel Trolley Heber hat eine speziell konstruierte Hubanordnung, die unter den Wheel Trolley passt, wodurch Trolley und Rad gemeinsam angehoben werden.

## SOLLEVATORE CARRELLO RUOTE SEMI-AUTOMATICO

Abbiamo sviluppato un sollevatore semi-automatico che, se combinato a sollevatori ruote completamente automatici posizionati sullo stesso piano, viene utilizzato per portare le ruote alla stessa altezza dello stallonatore o dello smontagomme. Il sollevatore Carrello Ruote solleva da 1 a 4 ruote orizzontalmente su un Carrello Ruote.

### COMPATIBILE CON I CARRELLI RUOTE

Il Carrello Ruote dispone di un dispositivo di sollevamento appositamente progettato per essere montato sotto al Carrello stesso, per mezzo del quale il carrello e le ruote vengono sollevati insieme.



## WHEEL TROLLEY LIFT



Semiautomatic wheel trolley lift for 4 wheels and a Wheel Trolley.

The wheel trolley is rolled over the wheel trolley lift. After that, using the foot pedal the trolley and wheels can be raised to ergonomic working height, thereby saving many heavy lifts. Stepless lift 0 - 700 mm.

### COLOURS



7016

## WHEEL TROLLEY HEBER

Halbautomatischer Radheber für 4 Räder einschl. Wheel Trolley.

Der Wheel Trolley wird über den Radheber gerollt, woraufhin man mit dem Fußpedal Trolley und Rad auf die ergonomische Arbeitshöhe heben und viel schweres Anheben sparen kann. Stufenlose Hebung 0 - 700 mm.

### VEHICLE



CAR VAN 4X4

## SOLLEVATORE CARRELLO RUOTE

Sollevatore carrello ruote semi-automatico per 4 ruote e un Carrello Ruote.

Il carrello ruote viene fatto rotolare sopra al sollevatore carrello ruote. In seguito, tramite l'azione del pedale, il carrello e le ruote possono essere sollevati ad un'altezza di lavoro ergonomica, evitando in questo modo le numerose operazioni gravose di sollevamento. Sollevatore continuo 0 - 700 mm.

### LIFTING HEIGHT



700 MM/27.5"

MODEL	ITEM NO.	DIMENSIONS (H) X (W) X (L)
WHEEL TROLLEY LIFT	0-51102201/00	530 MM (H) X 430 MM (W) X 1.100 MM (L) / 20.9" (H) X 16.9" (W) X 43.3" (L)

## WHEEL TROLLEY

A clever transport unit for wheels and tyres, designed for either 8 tires or 4 complete wheels.

The Wheel Trolley is compatible with several different types of lifting equipment that can be used to raise the Wheel Trolley up and ensure an ergonomic working height



### VEHICLE



CAR VAN

## WHEEL TROLLEY

Cleveres Transportgerät für Räder und Reifen, das für 8 Reifen oder 4 Kompleträder ausgelegt ist.

Wheel Trolley ist mit mehreren verschiedenen Arten von Hubgeräten kompatibel, die genutzt werden können, um den Wheel Trolley anzuheben und so eine ergonomische Arbeitshöhe zu gewährleisten.

### MAX LOAD



120 KG/265 LBS

## CARRELLO RUOTE

Un'unità di trasporto intelligente per ruote e pneumatici, progettata per 8 pneumatici o 4 ruote complete.

Il Carrello Ruote è compatibile con diversi tipi di attrezzature di sollevamento che possono essere utilizzate per sollevare il Carrello Ruote e garantire un'altezza di lavoro ergonomica.

MODEL	ITEM NO.	DIMENSIONS
WHEEL TROLLEY BASIC 6-PACK	0-51116901/00	H: 110 MM / 4.3", Ø: 630 MM / 24.8"

# WHEEL TROLLEY EASY LIFT



## AUTOMATIC ADJUSTMENT OF THE HEIGHT IN RELATION TO THE LOAD

Wheel Trolley Easy Lift is an elevated Wheel Trolley, which, with the help of springs, raises and lowers in relation to load. A brilliant feature, when you wish to save yourself for heavy lifting and relieve knees and back.

The Wheel Trolley Easy Lift can improve the work environment considerably when handling wheels.

By using the Wheel Trolley Easy lift you achieve good ergonomics for a small investment.

## HEBT UND SENKT SICH AUTOMATISCH IN BEZUG AUF BELASTUNG

Der Wheel Trolley Easy Lift ist ein erhöhter Wheel Trolley, der sich im Verhältnis zu dem Gewicht, das auf der oberen Fläche platziert wird, hebt und senkt. Eine geniale Eigenschaft, wenn man gerne unnötige Hebevorgänge sparen und die Knie und den Rücken entlasten möchte.

Der Wheel Trolley Easy Lift kann die Arbeitshaltung beim Reifenservice wesentlich verbessern.

Mit dem Wheel Trolley Easy Lift erhält man gute Ergonomie für eine kleine Investition.

## REGOLAZIONE AUTOMATICA DELL'ALTEZZA IN BASE AL CARICO

Il Wheel Trolley Easy Lift è un sollevatore ruota che, con l'ausilio di molle, solleva e abbassa la ruota in base al carico (peso). Una brillante caratteristica quando desiderate evitare di sollevare pesi per preservare ginocchia e schiena.

Il Wheel Trolley Easy Lift può migliorare in modo considerevole il luogo di lavoro quando si maneggiano delle ruote.

Utilizzando il Wheel Trolley Easy Lift potete ottenere una buona ergonomia a fronte di un piccolo investimento.



Patent pending PA 2018 00299

### WHEEL TROLLEY EASY LIFT

An elevated Wheel Trolley that raises and lowers in relation to load.

The Easy Lift is designed for 4 wheels and may be used for, amongst others, the mounting/dismounting of wheels.

The Wheel Trolley Easy Lift improves the ergonomics when handling wheels.

### WHEEL TROLLEY EASY LIFT

Ein erhöhter Wheel Trolley, der sich hebt und senkt je nach der Belastung.

Der Easy Lift ist für 4 Räder ausgelegt, und kann u. a. bei der Demontage und Montage von Reifen eingesetzt werden.

Der Wheel Trolley Easy Lift verbessert die Ergonomie bei der Handhabung von Rädern.

### WHEEL TROLLEY EASY LIFT

Il Wheel Trolley Easy Lift è un sollevatore ruota che solleva e abbassa la ruota in base al carico (peso). E' concepito per 4 ruote e può essere utilizzato, tra l'altro, per il montaggio e smontaggio delle ruote.

Il Wheel Trolley Easy Lift migliora l'ergonomia quando si maneggiano ruote.

#### VEHICLE



CAR VAN 4X4

#### MAX LOAD



180 KG/400 LBS

#### DIAMETER



Ø700 MM/27.6 INCH

#### HEIGHT



240 - 580 MM / 9.4 - 22.8 INCH

MODEL	ITEM NO.	DIMENSIONS
WHEEL TROLLEY EASY LIFT, 1 PC.	0-51120601/00	H: 240 - 580 MM / 9.4 - 22.8 INCH, Ø700 MM / 27.6 INCH

Automatic adjustment of the height according to the load placed on the top



MADE IN DENMARK

# LIFTING ROLLER TABLES



## LIFTING ROLLER TABLES

Our roller tables are available in versions with different types of lifts. Including the smart Vario lift, which is the logical ergonomic link between the tyre changer and the inflation station. Vario lift is designed in 2 versions – you can read more about these versions on the following page.

On the whole, all our roller tables are supplied with steel rollers of the highest quality. The roller surface is made of soft plastic and is fitted with smooth-running steel ball bearings to withstand maximum weight load.

## ROLLENTISCHE MIT HEBER

Unsere Rollentische sind in Varianten mit verschiedenen Formen für Heber erhältlich. Darunter das intelligente Vario Hubtisch, das ein logisches und ergonomisches Bindeglied zwischen Reifenmontiermaschine und Pumpenportal ist. Das Vario Hubtisch wurde in 2 Varianten entwickelt – du kannst mehr über diese 2 Variante auf die nächste Seite lesen.

Insgesamt gilt, dass alle unsere Rollentische mit Stahlrollen höchster Qualität versehen sind. Die Oberfläche der Rollen ist aus weichem Plastik und mit leichtlaufenden Stahlkugellagern montiert, um einer maximalen Gewichtsbelastung widerstehen zu können.

## TAVOLE A RULLI DI SOLLEVAMENTO

Le nostre tavole a rulli sono disponibili in versioni con diversi tipi di sollevatori; tra i quali il sollevatore intelligente Vario, che rappresenta il link ergonomico tra lo smontagomme e la stazione di gonfiaggio. Il sollevatore Vario è progettato in 2 versioni: per ulteriori informazioni si rimanda alla pagina seguente.

Nel complesso, tutte le nostre tavole a rulli vengono fornite con rulli in acciaio di altissima qualità. Il rullo, con superficie in plastica morbida, è provvisto di cuscinetti a sfera in acciaio altamente scorrevoli per sopportare il massimo carico.



## VARIO LIFT VL 700

Roller table with a specially designed lift.

The lift has a modified angle of 25 degrees that fits the angle of certain kinds of tyre changers. From the angle of 25 degrees the wheel can be lifted up to horizontal position

### COLOURS



7016

## VARIO HUBTISCH VL 700

Rollentisch mit einem spezial entwickelten lift.

Der lift ist an einen 25 Grad Winkel angepasst und passt damit an speziellen Arten von Montier-Geräten. Von diesem Winkel kann das Rad in eine waagerechte Position gehobt werden.

### VEHICLE



CAR VAN 4X4

## SOLLEVATORE VARIO VL 700

Tavola a rulli con sollevatore dedicato.

Il sollevatore ha un'angolazione modificata di 25 gradi che si adatta all'angolazione di alcuni tipi di smontagomme. Dall'angolazione di 25 gradi, la ruota può essere sollevata fino a raggiungere la posizione orizzontale

### LIFTING HEIGHT



310 MM/12.2"



MODEL	ITEM NO.	DIMENSIONS (H) X (W) X (L)
VL 700	0-51102301/00	700 MM (H) X 700 MM (W) X 1.600 MM (L) / 27.5" (H) X 27.5" (W) X 63" (L)

## VARIO LIFT VL 900

For secure lifting and moving of the wheel from tyre changer to inflation station. Suitable for several tyre changers with „Center-Clamping“.

### COLOURS



7016

## VARIO HUBTISCH VL 900

Für den sicheren Hub und zur Weiterführung des Rades vom Montiergerät zur Befüllstation. Für viele Montiergeräte mit Zentraler Spannvorrichtung geeignet.

### VEHICLE



CAR VAN 4X4

## SOLLEVATORE VARIO VL 900

Per il sollevamento e lo spostamento in sicurezza della ruota dallo smontagomme alla stazione di gonfiaggio. Adatto per diversi tipi di smontagomme con "Bloccaggio Centrale".

### LIFTING HEIGHT



480 MM/18.9"



MODEL	ITEM NO.	DIMENSIONS (H) X (W) X (L)
VL 900	0-51102401/00	700 MM (H) X 700 MM (W) X 1.600 MM (L) / 27.5" (H) X 27.5" (W) X 63" (L)



### WHEEL LIFT FLIP LIFT

The Flip lift is a semiautomatic wheel lift. Place the wheel on the front and operate with the handswitch. The lift has a dual function. Fits all our roller tables.

#### COLOURS



7016

### RADHEBER FLIP LIFT

Der Flip Lift ist ein semiautomatischer Radheber. Das Rad wird vorn platziert und der Lift wird per handswitch bedient. Der lift hat zweiwege Funktion. Passend für alle unsere Rollentische.

#### VEHICLE



CAR VAN 4X4

### SOLLEVATORE RUOTE FLIP

Il sollevatore Flip è del tipo semi-utomatico. Posizionare la ruota sulla parte anteriore e agire sull'interruttore manuale. Il sollevatore ha una duplice funzione. Si adatta a tutte le nostre tavole a rulli.

#### MAX LOAD



65 KG/143 LBS

MODEL	ITEM NO.	DIMENSIONS (H) X (W) X (L)
FLIP LIFT	0-51102501/00	750 MM (L) X 600 MM (W) / 29.5" (L) X 23.6" (W)



### WHEEL LIFT SWING LIFT

Swing Lift is installed behind the balancing machine for fast and ergonomic further handling of the wheel. The lift has auto start. Can only be used together with WCL 700 and Roll-out ramp respectively.

#### COLOURS



7016

### RADHEBER SWING LIFT

Der Swing Lift wird für eine schnelle und ergonomische Weiterbearbeitung des Rades hinter der Auswuchtmaschine montiert. Der Lift ist mit einem Autostart versehen. Lässt sich nur zusammen mit WCL 700 beziehungsweise Ausrollrampe verwenden.

#### VEHICLE



CAR VAN 4X4

### SOLLEVATORE RUOTE SWING

Il Sollevatore Swing viene installato dietro all'equilibratrice per una gestione veloce ed ergonomica della ruota. Il sollevatore ha la funzione di avvio automatico. Può essere utilizzato unicamente con WCL 700 e Rampa di lancio rispettivamente.

#### MAX LOAD



65 KG/143 LBS

MODEL	ITEM NO.	DIMENSIONS (H) X (W) X (L)
SWING LIFT	0-51102601/00	700 MM (H) X 660 MM (W) X 2.300 MM (L) / 27.5" (H) X 26" (W) X 90.5" (L)



 **MADE IN DENMARK**

# CENTERING LIFT



## CENTERING LIFT

The WCL Centering lift is designed for lifting the wheel for "weightless" clamping on the balancing machine mandrel. Model WCL700 is self-adjusting according to height.

A centering lift is indispensable in an assembly line because it takes care of the heavy lifting of the wheel and at the same time supports it until the wheel is mounted on the balancing machine. The lift fits most balancing machines.

## ZENTRIERUNGSHEBER

Der WCL-Zentrierungsheber ist zum Anheben des Rades zum „schwerelosen“ Aufspannen auf der Achse der Auswuchtmaschine vorgesehen.

Das Modell WCL700 stellt sich selbst in der Höhe ein.

Ein Zentrierungsheber ist eine große Hilfe auf einer Montagestraße, da sie sich teils des schweren Hebens des Rades annimmt und es gleichzeitig abstützt, bis das Rad auf der Auswuchtmaschine aufgespannt ist. Der Heber passt zu den meisten Auswuchtmaschinen

## SOLLEVATORE DI CENTRAGGIO

Il sollevatore di centraggio WCL è stato progettato per il sollevamento della ruota per un bloccaggio "in assenza di peso" sul mandrino dell'equilibratrice.

Il modello WCL700 dispone della funzione di auto-adattamento in base all'altezza.

Un sollevatore di centraggio rappresenta un elemento indispensabile in una linea di montaggio in quanto provvede al sollevamento gravoso della ruota e, allo stesso tempo, la supporta fino al momento in cui la stessa viene montata sull'equilibratrice. Il sollevatore si adatta alla maggior parte delle equilibratrici.

## CENTERING LIFT WCL 700

Centering lift for "weightless" clamping of wheels on the balancing machine. Fits almost all models of balancing machines.

Incl. 1.150 mm lifting rail with a turntable for a 180 degree rotation of the wheel.

### COLOURS



7016

## ZENTRIERUNGSHEBER WCL 700

Zentrierungsheber für „schwere lose“ Aufspannung von Rädern auf die Achse der Auswuchtmaschine. Eignet sich für fast alle Modelle von Auswuchtmaschinen.

Einschl. 1.150 mm Hebeschiene mit Drehplatte für eine 180-Grad-Drehung des Rades

### VEHICLE



MC CAR VAN 4X4

## SOLLEVATORE DI CENTRAGGIO WCL 700

Sollevatore di centraggio per il bloccaggio "in assenza di peso" delle ruote sull'equilibratrice. Si adatta a quasi tutti i modelli di equilibratrici. Comprensivo di binario di sollevamento da 1.150 mm con piatto autocentrante per una rotazione di 180 gradi della ruota.

### MAX LOAD



100 KG/220 LBS

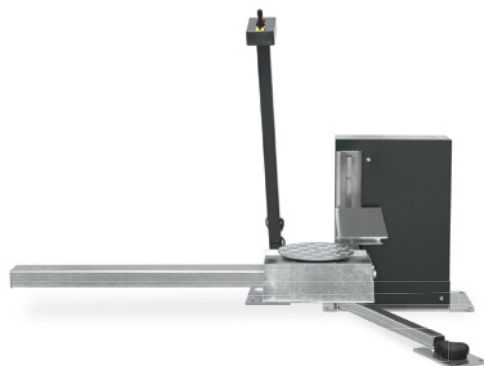

MODEL	ITEM NO.	DIMENSIONS (H) X (W) X (L)
WCL 700	0-51102801/00	1.150 MM (H) X 1.360 MM (W) X 680 MM (L) / 39.4" (H) X 53.5" (W) X 26.8" (L)



The wheel is rotated into position on the revolving platform and using the foot pedal it is then lifted to the correct height in relation to the balancing machine. This way the mechanic avoids inconvenient lifting and twisting of the back. WCL 700 comes with a 1.150 mm lifting rail.

Auf der Drehscheibe wird das Rad in Position gedreht, und mit dem Fußpedal wird das Rad auf die korrekte Höhe im Verhältnis zur Auswuchtmaschine gehoben. Damit vermeidet der Mechaniker die unzweckmäßigen Hebevorgänge und Verrenkungen des Rückens. Der WCL wird inklusive einer 1.150 mm langen Hubschiene geliefert.

La ruota viene ruotata in posizione sulla piattaforma rotante, quindi viene sollevata tramite il pedale alla giusta altezza in base all'equilibratrice utilizzata. In questo modo il meccanico evita di eseguire una scomoda operazione di sollevamento e una torsione della schiena. WCL 700 viene fornito con un binario di sollevamento da 1.150 mm.

# BEAD BREAKERS



## BEAD BREAKERS

A key component of the equipment for an optimised workflow when handling tyres is the semi-automatic bead breaker. Our bead breakers press the tyre to remove the rim horizontally.

This method ensures a much lower number of pressure damages to the rim and a much better working posture compared with the use of traditional vertical bead breakers.

The bead breakers are equipped with a functional wheel turning plate, which ensures that you can easily and effortlessly turn the wheel while working – completely without having to lift the entire wheel.

## REIFENABDRÜCKER

Ein ganz zentraler Teil der Ausrüstung für den optimierten Arbeitsablauf bei der Arbeit mit Reifen sind die halbautomatischen Reifenabdrücker. Unsere Reifenabdrücker drücken den Reifen in horizontaler Richtung von der Felge ab.

Diese Methode führt sowohl zu erheblich weniger Druckschäden an der Felge als auch einer wesentlich besseren Arbeitshaltung im Vergleich zum Gebrauch der herkömmlichen vertikalen Reifenabdrücker.

Die Reifenabdrücker sind mit einer funktionalen Raddrehplatte versehen, die sichert, dass man einfach und unbeschwert das Rad während der Arbeit wenden kann – ohne dass das gesamte Gewicht des Rades angehoben werden muss.

## STALLONATORI

Lo stallonatore semi-automatico rappresenta un componente chiave per l'attrezzatura di un flusso di lavoro ottimizzato nella movimentazione degli pneumatici. I nostri stallonatori esercitano una pressione sullo pneumatico per rimuovere il cerchio orizzontalmente.

Questo metodo garantisce una considerevole diminuzione dei danni al cerchio dovuti alla pressione e una postura considerevolmente migliore rispetto all'uso di stallonatori verticali.

Gli stallonatori sono dotati di una piastra rotante funzionale per ruote che garantisce l'esecuzione di una rotazione semplice e senza sforzi della ruota durante il lavoro, senza dover sollevare l'intera ruota.



## BEAD BREAKER BBRT 900

Horizontal bead breaker for car and C-van tyres.  
Including wheel turning plate that allows turning the wheel 180 degrees without lifting it. Also incl. tool box and magic arm for hold on alloy rims.  
2 level adjustments of the wheel.

### COLOURS

7016



9006

## REIFENABDRÜCKER BBRT 900

Horizontaler Reifenabdrücker für PKW- und Transporterreifen.  
Einschl. Drehteller womit das Rad einfach ohne Anheben um 180 Grad gewendet werden kann. Auch einschl. Werkzeugsregal und magischer Arm für Gegenhalt an Alu-Felgen.  
2 Höheneinstellungen vom Rad.

### VEHICLE



## STALLONATORE BBRT 900

Stallonatore orizzontale per pneumatici auto e furgoni di tipo C.  
Comprensivo di piastra rotante ruote per una rotazione di 180 gradi della ruota senza doverla sollevare. Comprende inoltre una cassetta attrezzi e il braccio magico per i cerchi in lega. 2 livelli di regolazione della ruota.

MODEL	ITEM NO.	DIMENSIONS (H) X (W) X (L)
BBRT 900	0-51103001/00	1.350 MM (H) X 780 MM (W) X 1.300 MM (L) / 53.1" (H) X 30.7" (W) X 51.2" (L)



Wheel turning plate with swinging support arm



Holder for mounting paste and knife

### OPTIONS / ZUBEHÖR / OPTIONAL / BEAD BREAKER

<input type="checkbox"/>	WHEEL TURNING PLATE	0-51103201/00
<input type="checkbox"/>	HOLDER FOR MOUNTING PASTE	0-51103401/00
<input type="checkbox"/>	SPRING HOLDER	0-51103501/00
<input type="checkbox"/>	TOOL BOX	0-51103601/00



Spring holder for air tool incl. pump hose



Tool box with 5 shelves



7016

# INFLATION STATIONS

## INFLATION STATIONS

Inflation stations are used for safe inflation of passenger car and C-van tyres where the fitter is protected in the event of a tyre burst.

The inflation stations are simply an indispensable part of a professional tyre service centre - both with respect to optimising the workflow, and in relation to improving ergonomics and increasing safety.

## BEFÜLLSTATIONEN

Befüllstationen werden zum sicheren Befüllen von PKW- und Transporterreifen verwendet, wobei dem Monteur Schutz geboten wird, falls ein Reifen explodiert.

Die Befüllstationen sind schlicht ein unverzichtbarer Teil einer professionellen Reifenwerkstatt – sowohl in Bezug auf die Optimierung des Arbeitsablaufs als auch auf die Verbesserung der Ergonomie und die Steigerung der Sicherheit.

## STAZIONI DI GONFIAGGIO

Le stazioni di gonfiaggio vengono utilizzate per il gonfiaggio sicuro degli pneumatici di auto e furgoni di tipo C dove il montatore è protetto in caso di scoppio dello pneumatico.

Le stazioni di gonfiaggio rappresentano semplicemente un elemento indispensabile di un centro professionale di assistenza pneumatici, sia per l'ottimizzazione del ciclo di lavoro che per il miglioramento dell'ergonomia d'uso e la maggiore sicurezza.







## INFLATION STATION IT 200+

Complete inflation station for safe inflation of wheels. Roller table with an open safety portal and PCI 900/7 Bar computer inflator.

### COLOURS



7016

MODEL	ITEM NO.	DIMENSIONS (H) X (L) X (D)
IT 200+	0-51120101/00	1.468 MM (H) X 1.950 MM (L) X 777 MM (D) / 57.8" (H) X 76.8" (L) X 30.6" (D)

## BEFÜLLSTATION IT 200+

Komplette Befüllstation für das sichere Befüllen von Rädern. Rollentisch mit einem offenen Sicherheitsportal und PCI 900/7 Bar Befüllcomputer.

### VEHICLE



## STAZIONE DI GONFIAGGIO IT 200+

Stazione di gonfiaggio completa per il gonfiaggio in sicurezza degli pneumatici. Tavola a rulli con portale di sicurezza aperto e dispositivo di gonfiaggio computerizzato PCI 900/7 Bar.

### SAFETY

SAFETY GLASS -  
POLYCARBONATE

## INFLATION STATION IT 700+

Complete inflation station for the inflation of wheels. Roller table with safety portal. PCI 1200/7 Bar computer inflator. 4 programs. Omega-Jet system with wheel lifting device. Spring holder for air hose.

### COLOURS

7016



9006

## BEFÜLLSTATION IT 700+

Komplette Befüllstation zum Befüllen von Rädern. Rollentisch mit Sicherheitsportal. PCI 1200/7 Bar Befüllcomputer. 4 Programme. Omega-Jet System mit Radheber Federhalter für Druckschlauch.

### VEHICLE



## STAZIONE DI GONFIAGGIO IT 700+

Stazione di gonfiaggio completa per il gonfiaggio degli pneumatici. Tavola a rulli con portale di sicurezza. Dispositivo di gonfiaggio computerizzato PCI 1200/7 Bar. 4 programmi. Sistema Omega Jet con dispositivo di sollevamento ruote. Supporto elastico per tubo aria.

### SAFETY

SAFETY GLASS -  
POLYCARBONATE

MODEL	ITEM NO.	DIMENSIONS (H) X (W) X (L)
IT 700+	0-51121101/00	1.670 MM (H) X 1.020 MM (W) X 2.385 MM (L) / 65.7" (H) X 40.2" (W) X 93.9" (L)
SAFETY GATE	0-51105401/00	

**MAXIMIZED SAFETY WHEN INFLATING WHEELS**



IT 1000 mounted with 2 safety gates, extension tables and Omega Jet System



## INFLATION STATION IT 1000

New streamlined inflation station for safe inflation of wheels.

IT 1000 is constructed as a basic model with a PCI 1200 computer inflator. IT 1000 can be mounted with different kinds of optional equipment. This way you can have an inflation station with exactly the features and functions you need.

The safety using IT 1000 is improved compared to our former models of inflation stations, and the design has been streamlined.

## BEFÜLLSTATION IT 1000

Neue stromlinienförmige Befüllstation für das sichere Befüllen von Rädern.

IT 1000 ist als Basismodell mit einem PCI 1200 Befüllcomputer verfügbar. IT 1000 kann mit unterschiedlicher Ausrüstung montiert werden. So erhält man genau die Befüllstation, die den eigenen Bedürfnissen und Wünschen entspricht.

Die Sicherheit der Nutzung der IT 1000 ist verbessert wenn man mit unseren früheren Modellen vergleicht, und das Design ist aktualisiert worden.

## STAZIONE DI GONFIAGGIO IT 1000

Nuova stazione di gonfiaggio efficiente per il gonfiaggio in sicurezza degli pneumatici.

IT 1000 è costruita come modello base con un dispositivo di gonfiaggio computerizzato PCI 1200. IT 1000 può essere montata con diversi tipi di attrezzature opzionali. In questo modo è possibile ottenere una stazione di gonfiaggio che abbia esattamente le caratteristiche e le funzioni necessarie. L'utilizzo di IT 1000 migliora la sicurezza rispetto ai nostri precedenti modelli di stazioni di gonfiaggio e il design è stato alleggerito e razionalizzato.

### COLOURS



7016 9006 3002 5015

### VEHICLE



MC CAR VAN 4X4

### SAFETY



SAFETY GLASS - POLYCARBONATE



H: 780 MM/30.7"  
W: 400 MM/15.7"

MODEL	ITEM NO.	DIMENSIONS (H) X (W) X (L)
IT 1000 INCL. PCI 1200	0-51100201/00	1.235 MM (H) X 1.000 MM (W) X 1.100 MM (L) / 48.6" (H) X 39.4" (W) X 43.3" (L)

OPTIONS / ZUBEHÖR / OPTIONAL //INCL. INSTALLATION	ITEM NO.
<input type="checkbox"/> OMEGA JET SYSTEM, 30 LITRE TANK	0-51100301/00
<input type="checkbox"/> SAFETY GATE, RIGHT SIDE	0-51100401/00
<input type="checkbox"/> SAFETY GATE, LEFT SIDE	0-51100501/00
<input type="checkbox"/> EXTENSION TABLE 350	0-51103901/00
<input type="checkbox"/> EXTENSION TABLE 700	0-51100701/00
<input type="checkbox"/> EXTENSION TABLE 500 W/TILT	0-51104001/00
<input type="checkbox"/> WARNING LIGHT, ORANGE	0-51112201/00
<input type="checkbox"/> AUDIBLE ALARM, SOUND AND WARNING LIGHT, RED	0-51112301/00
<input type="checkbox"/> EXTRA PCI 1200/7 BAR COMPUTER INFLATOR	0-51111401/00
<input type="checkbox"/> PCI HOLDER FOR EXTRA PCI 1200	0-51111301/00

## OPTIONS / ZUBEHÖR / OPTIONAL //IT 1000

**PNEUMATIC OMEGA JET SYSTEM**

The pneumatic Omega Jet System uses a boost of air to make the bead have the right seat on the rim.

- Flowoptimized pneumatic Omega Jet System
- 30 litre pressure tank = Reinforced jet function

**PNEUMATISCHES OMEGA-JET-SYSTEM**

Das pneumatische Omega-Jet-System verwendet einen Luftstoß um der Platzierung des Reifens auf der Felge zu optimieren.

- Flow-optimiertes pneumatisches Omega-Jet-System
- 30 Liter Drucktank = verstärkte Jet-Funktion

**SISTEMA PNEUMATICO OMEGA JET**

Il sistema pneumatico Omega Jet utilizza un getto d'aria per consentire al tallone di essere correttamente posizionato sul cerchio.

- Sistema pneumatico Omega Jet a flusso ottimizzato
- Serbatoio a pressione da 30 litri = getto rinforzato Funzione

**EXTENSION TABLE 700**

This extension table with legs can be mounted on the inflation station in both ends, where it secures a good workflow on the mounting line.

- Makes room for the helping arm of the tyre changer
- More space for wheels – and this way a better workflow on the line
- Possible to have more concurrent workflows, such as bead breaking, tyre mounting and inflation

**VERLÄNGERUNGSTISCH 700**

Diesen Verlängerungstisch mit Beinen kann auf beiden Seiten der Befüllstation montiert werden.

- Macht Platz für den Hilfsarm von der Reifenmontiermaschine
- Mehr Platz für die Räder – und damit ein verbessertes Workflow auf die Montagestraße
- Möglich mehrere gleichzeitige Aufgaben auszuführen – wie Abdrücken, Reifenmontage und Befüllen

**TAVOLA DI PROLUNGA 700**

Questa tavola di prolunga dotata di gambe può essere montata da entrambi i lati della stazione di gonfiaggio, dove garantisce un buon flusso di lavoro sulla linea di montaggio.

- Crea spazio per il braccio dello smontagomme
- Più spazio per le ruote, ovvero un migliore flusso di lavoro sulla linea
- Possibilità di avere più flussi di lavoro in contemporanea, ovvero stallonatura, montaggio e gonfiaggio pneumatici

**PNEUMATISCHE SICHERHEITSTÜRE**

IT 1000 kann mit pneumatischen Sicherheitstüren montiert werden. Diese Türe bieten den Optimalen Schutz während des Befüllen von Rädern an.

- Schließen automatisch wenn die Befüll Zyklus aktiviert werden
- Bieten optimaler Schutz vor Montier-pasta und andere Fragmente

**PNEUMATIC SAFETY GATES**

IT 1000 can be mounted with pneumatic safety gates, that offers optimal protection during inflation.

- Closes automatically when activating the inflation cycle
- Offers optimal protection against mounting paste and other fragments

**CANCELLI PNEUMATICI DI SICUREZZA**

IT 1000 può essere montata con cancelli pneumatici di sicurezza, per una protezione ottimale durante il gonfiaggio.

- Si chiude automaticamente all'attivazione del ciclo di gonfiaggio
- Offre una protezione ottimale contro la pasta di montaggio e altri frammenti

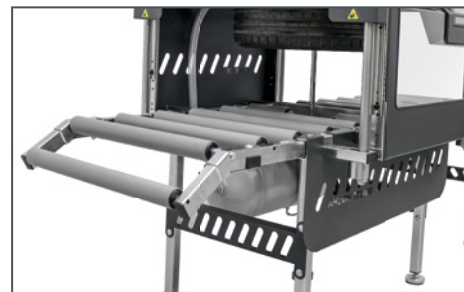
**EXTENSION TABLE 500**

Thanks to the drop with an angle of 35 degrees, this extension table secures a good ergonomic connection to the next element of the mounting line.

- Is used on the left side of the inflation station for improved ergonomics

**VERLÄNGERUNGSTISCH 500**

Dank dem Gefallen mit einem Winkel von 35 Grad, sichert diesen Verlängerungstisch eine gute ergonomische Übergang zu der nächster Element in der Montage Straße.

- Wird auf die linke Seite der Befüllstation erwendet – für eine verbesserte Ergonomie

**TAVOLA DI PROLUNGA 500**

Grazie all'inclinazione con angolazione di 35 gradi, questo piano inclinato assicura una buona connessione ergonomica all'elemento successivo della linea di montaggio.

- Viene utilizzato sul lato sinistro della stazione di gonfiaggio per una migliore ergonomia d'uso

# ROLLER TABLES



## ROLLER TABLES

Roller tables are an important element in an assembly line, where ergonomics and good workflow must be ensured. The roller tables guarantee that the wheels can be fed forward effortlessly from unit to unit in the assembly line.

On the whole, all roller tables are supplied with steel rollers of the highest quality.

The roller surface is made of soft plastic and is fitted with smooth-running steel ball bearings to withstand maximum weight load.

## ROLLENTISCHE

Rollentische sind ein wichtiges Element in einer Montagestraße, wenn Ergonomie und guter Arbeitsablauf gesichert werden müssen. Die Rollentische gewährleisten, dass die Räder einfach und unbeschwert von einer Einheit auf der Montagestraße zur nächsten weitergeführt werden können.

Insgesamt gilt, dass alle Rollentische mit Stahlrollen höchster Qualität versehen sind.

Die Oberfläche der Rollen ist aus weichem Plastik und mit leichtlaufenden Stahlkugellagern montiert, um einer maximalen Gewichtsbelastung widerstehen zu können.

## TAVOLE A RULLI

Le tavole a rulli rappresentano un elemento importante all'interno di una linea di montaggio, dove devono essere garantiti l'ergonomia d'uso e un buon flusso di lavoro.

Le tavole a rulli assicurano che le ruote possano essere movimentate in avanti senza sforzo da unità a unità lungo la linea di montaggio.

Nel complesso, tutte le tavole a rulli vengono fornite con rulli in acciaio di altissima qualità.

Il rullo, con superficie in plastica morbida, è provvisto di cuscinetti a sfera in acciaio altamente scorrevoli per sopportare il massimo carico.

## ROLLER TABLES

Roller tables with galvanized legs and steel rollers.

The roller tables can be combined with more of our equipment to a complete assembly line.

### COLOURS



7016



Supply table for 3 wheels.  
Has a variable gradient of 3-10°



For stable and durable connection of roller tables.



Roller set with 2 rollers with a drop of 35°, which provides the perfect ergonomic transition to, for example, the WCL or the balancing machine in the assembly line.



Extension table 500 is with 4 steel rollers. The last 2 rollers have a drop of 35° so that the table provides the perfect ergonomic transition to, for example, the balancing machine in the assembly line.



Extension table 600 is with 1 set of galvanized legs and 5 pcs. steel rollers. The Extension table can be used in combination with the inflation stations and other products in an assembly line.

## ROLLENTISCHE

Rollentische mit galvanisierten Stützen und Stahl Rollen.

Die Rollentische werden mit weiterem Gerät zu einer kompletten Montagestraße kombiniert.

### VEHICLE



MC CAR VAN 4X4

## TAVOLE A RULLI

Tavole a rulli con gambe zincate e rulli in acciaio. Le tavole a rulli possono essere abbinate a diverse delle nostre attrezzature per completare una linea di montaggio.

### MAX LOAD



65 KG/143 LBS

MODEL	ITEM NO.	DIMENSIONS (H) X (W) X (L)
ROLLER TABLE 600 (L)	0-51107601/00	700 MM (H) X 660 MM (W) X 585 MM (L) / 27.5" (H) X 26" (W) X 23" (L)
ROLLER TABLE 900 (L)	0-51107701/00	700 MM (H) X 660 MM (W) X 890 MM (L) / 27.5" (H) X 26" (W) X 35" (L)
ROLLER TABLE 1200 (L)	0-51107801/00	700 MM (H) X 660 MM (W) X 1.285 MM (L) / 27.5" (H) X 26" (W) X 50.6" (L)
ROLLER TABLE 1500 (L)	0-51107901/00	700 MM (H) X 660 MM (W) X 1.545 MM (L) / 27.5" (H) X 26" (W) X 60.8" (L)
ROLLER TABLE 1630 (L) 3-10 degrees	0-51108501/00	700 MM (H) X 660 MM (W) X 1.630 MM (L) / 27.5" (H) X 26" (W) X 64.2" (L)

### OPTIONS / ZUBEHÖR / OPTIONAL / ROLLER TABLES

<input type="checkbox"/>	ASSEMBLY FITTING	0-51108301/00
<input type="checkbox"/>	ROLLER SET	0-51108401/00
<input type="checkbox"/>	EXTENSION TABLE 500	0-51108101/00
<input type="checkbox"/>	EXTENSION TABLE 600	0-51108201/00

# TYRE SEAT OPTIMIZING

## TYRE SEAT OPTIMIZING

In order to optimize the tyre placement on the rim and remove the so-called "flat spots" on the tyre, we have designed Match Matic 900.

Match Matic simulates driving on the road, and using computer controlled programs with a duration of 30 to 120 seconds, adjustable pressure is applied on the side wall and tread.

This helps optimize tyre homogeneity and reduce "flat spots". Wheel optimization in Match Matic 900 results in fewer complaints and subsequent alignment.

## OPTIMIERUNG DES REIFENSITZES

Zur Optimierung der Reifenplatzierung auf der Felge sowie zum Entfernen der sogenannten „flat spots“ am Reifen haben wir Match Matic 900 entwickelt.

Match Matic simuliert die Fahrt auf der Straße, und mit Hilfe computergesteuerter Programme von 30 bis 120 Sekunden Dauer werden einstellbare Druckauswirkungen auf Seitenwände und Lauffläche vorgenommen. Damit werden die Homogenität des Reifens optimiert und „flat spots“ reduziert. Die Optimierung von Rädern im Match Matic 900 führt zu weniger Reklamationen und nachträglichem Auswuchten.

## OTTIMIZZAZIONE SEDE PNEUMATICO

Per ottimizzare il posizionamento dello pneumatico sul cerchio ed eliminare i cosiddetti "piatti" sullo pneumatico, abbiamo progettato Match Matic 900.

Match Matic simula la guida su strada e, tramite l'utilizzo di programmi controllati da PC di una durata da 30 a 120 secondi, sul fianco e sul battistrada viene applicata una pressione regolabile. Ciò aiuta ad ottimizzare l'omogeneità degli pneumatici e a ridurre i "piatti". Grazie all'ottimizzazione con Match Matic 900 si riscontra un numero inferiore di reclami e, conseguentemente, di allineamenti.

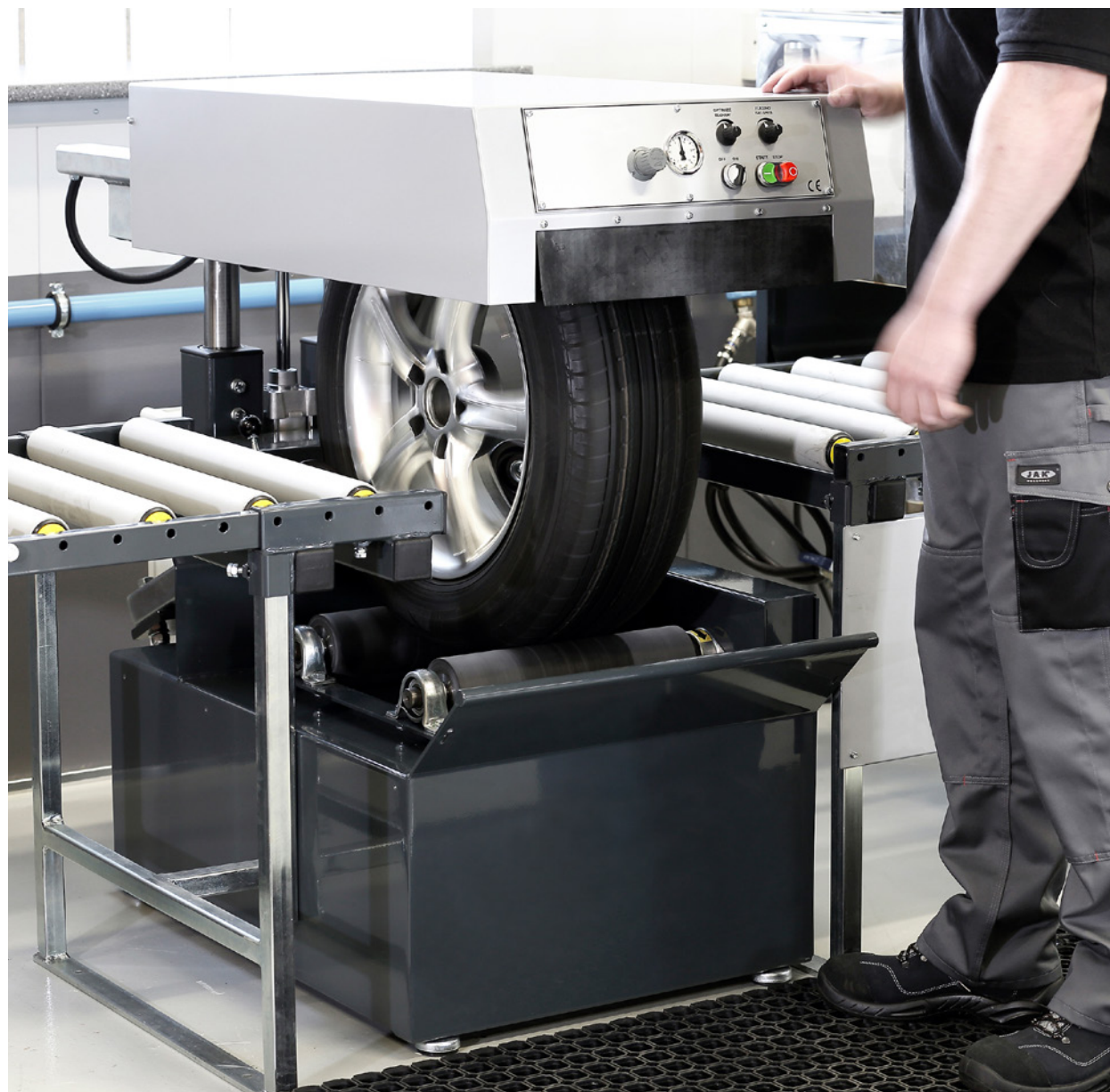

Match Matic is available as a "stand-alone unit" or for incorporating in an assembly line / Match Matic ist sowohl als unabhängige Maschine als auch als Einbau in eine Montagestraße erhältlich / Match Matic è disponibile come unità singola o come elemento da inserire all'interno di una linea di montaggio

## TYRE SEAT OPTIMIZING MATCH MATIC 900

Match Matic 900 optimizes the seat of the tyre on the rim. Reduces flat spots by among others simulating road conditions.

Adjustable pressure on sidewalls and tread. The use of Match Matic 900 reduces claims and rebalancing of mounted tyres.

### COLOURS

7016



9006



## REIFENSITZ OPTIMIERUNG MATCH MATIC 900

Match Matic 900 optimiert den Sitz des Reifens. Die Maschine Reduziert Flachstellen. Simuliert Strassenverhältnisse.

Einstellbarer Druck an der Reifenflanke und Lauffläche. Den Gebrauch vom Match Matic 900 reduziert Reklamationen und den Bedarf von erneuten Wuchten.

### COMPUTER PROGRAM



30 - 120 SEC.

## OTTIMIZZAZIONE SEDE PNEUMATICO MATCH MATIC 900

Match Matic 900 ottimizza la sede dello pneumatico sul cerchio. Riduce i piatti simulando, tra le altre cose, le condizioni su strada.

Pressione regolabile sui fianchi e sul battistrada. L'utilizzo di Match Matic 900 riduce i reclami e la ri-equilibratura degli pneumatici montati.

### VEHICLE



CAR VAN 4X4

MODEL	ENGINE	ITEM NO.	DIMENSIONS (H) X (W) X (L)
MATCH MATIC 900	3X220V 50 HZ	0-51108901/00	1.430 MM (H) X 620 MM (W) X 1.160 MM (L) / 56.3" (H) X 24.4" (W) X 45.7" (L)
MATCH MATIC 900	1X400V 50 HZ	0-51109001/00	1.430 MM (H) X 620 MM (W) X 1.160 MM (L) / 56.3" (L) X 24.4" (W) X 45.7" (L)
MATCH MATIC 900	3X240V 60 HZ	0-51109101/00	1.430 MM (H) X 620 MM (W) X 1.160 MM (L) / 56.3" (H) X 24.4" (W) X 45.7" (L)

## OPTIONS / ZUBEHÖR / OPTIONAL

### ROLLER BRIDGE / ROLLENBRÜCKE / PONTE A RULLI

Roller bridge for periodically omitting the use of Match Matic

Rollenbrücke für zeitweises Auslassen von Match Matic

Ponte a rulli per l'esclusione periodica dell'uso di Match Matic



#### ITEM NO.

0-51109201/00

### INFEED ROLLER TABLE / ZUSATSTISCH / TAVOLA A RULLI IN INGRESSO

For mounting on Match Matic in assembly line

Für die Montage auf Match Magic in der Montagestraße

Per il montaggio su Match Matic all'interno di una linea di montaggio



#### ITEM NO.

0-51109301/00

# POWER WALLS



## POWER WALLS

Power Wall Flex is a construction kit consisting of power wall modules. Each module is equipped with compressed air outlets and 2 outlets for connection.

The power walls are designed to provide an extra air tank that balances the consumption on the existing air supply, which in many cases is undersized in relation to the too many outlets and consumption.

The galvanised decor plate of the power walls serves as a tool board for pneumatic tools, amongst other things. That the walls are interconnected means that only 1 external air supply is required to supply the entire line of interconnected energy walls.

## ENERGIEWÄNDE

Power Wall Flex ist ein aus Energiewandmodulen bestehendes Bausystem. Jedes Modul ist mit Druckluftausgängen sowie zwei Ausgängen zum Zusammenkoppeln versehen. Die Energiewände wurden entwickelt, um einen zusätzlichen Lufttank zu bilden, der den Verbrauch der vorhandenen Luftzufuhr ausgleicht, die in vielen Fällen in Bezug auf zu viele Ausgänge und den Verbrauch unterdimensioniert ist.

Die verzinkte Dekorplatte der Energiewände funktioniert als Werkzeugtafel für u. a. Luftwerkzeug. Die Zusammenkopplung der Wände bedeutet, dass nur eine externe Luftzufuhr benötigt wird, um eine ganze Reihe von zusammengekoppelten Energiewänden zu versorgen.

## PARETI DI ALIMENTAZIONE

La Parete di Alimentazione Flex è un kit costruttivo costituito da moduli di pareti di alimentazione. Ogni modulo è dotato di uscite dell'aria compressa e 2 uscite di connessione. Le pareti di alimentazione sono state progettate per fornire un serbatoio aria extra che bilanci il consumo sull'alimentazione esistente dell'aria, che in molti casi potrebbe essere sottodimensionata rispetto alle troppe uscite e al consumo.

La piastra decorata zincata delle pareti di alimentazione funge da porta-attrezzi, tra i quali quelli pneumatici. L'interconnessione delle pareti significa che è necessaria solamente 1 fonte di alimentazione esterna dell'aria per alimentare l'intera linea di pareti di alimentazione interconnesse.





Flex series



Combi series

## POWER WALL FLEX & COMBI SERIES

Flex and Combi power wall modules are equipped with connectors for compressed air and with connectors for the connection to further energy wall modules.

### COLOURS



7016

## ENERGIEWAND FLEX & COMBI SERIE

Flex und Combi Energiewandmodule sind mit Anschlüssen für Druckluft und mit Verbindungsanschlüssen für die Verbindung mit weiteren Energiewandmodulen.

### MAX PRESSURE



12 BAR

## PARETI DI ALIMENTAZIONE SERIE FLEX E COMBI

I moduli di pareti di alimentazione Flex e Combi sono dotati di connettori per l'aria compressa e di connettori per il collegamento ad ulteriori moduli di pareti di alimentazione.

### MAX WHEEL SIZE

H: 900 MM/35.4"  
W: 280 MM/11"

MODEL	ITEM NO.	CONNECTORS FOR AIR	DIMENSIONS (H) X (W) X (L)
FLEX 1000	0-51109401/00	4 PCS.	1.050 MM (H) X 76 MM (W) X 1.020 MM (L) / 41.3" (H) X 3" (W) X 40.2" (L)
FLEX 1700	0-51109501/00	6 PCS.	1.050 MM (H) X 76 MM (W) X 1.720 MM (L) / 41.3" (H) X 3" (W) X 67.7" (L)
FLEX 2300	0-51109601/00	8 PCS.	1.050 MM (H) X 76 MM (W) X 2.340 MM (L) / 41.3" (H) X 3" (W) X 92.1" (L)
COMBI 2300	0-51109701/00	4 PCS.	1.360 MM (H) X 745 MM (W) X 2.300 MM (L) / 53.5" (H) X 29.3" (W) X 90.55" (L)
COMBI 2600	0-51109801/00	4 PCS.	1.360 MM (H) X 745 MM (W) X 2.600 MM (L) / 53.5" (H) X 29.3" (W) X 102.36" (L)
CONNECTING KIT	0-51109901/00		
ELECTRICAL POWER SET, BASIC	0-51110001/00		
ELECTRICAL POWER SET, COMBI	0-51110101/00		

# SAFETY INFLATION CAGES

## SAFETY INFLATION CAGES

A key part of our product range are safety inflation cages. The inflation cages are designed to protect the fitter when inflating tyres for trucks, busses and big wheels for off-road vehicles. The construction of our cages is based on our many years of experience. The cages are open at the top and closed at the bottom, and the sides are made of patented DUPLEX material that allows up to 70% stretch and breaks the air pressure in the event of an explosion.

The safety inflation cages come in several different sizes and designs, and with various accessories.

## SICHERHEITS-BEFÜLLKÄFIGE

Ein zentraler Teil des Produktprogramms sind Sicherheits-Befüllkäfige. Die Befüllkäfige sind zum Schutz des Monteurs beim Befüllen von Reifen für LKW, Busse und ganz große Reifen für Geländefahrzeuge ausgelegt.

Der Aufbau unserer Käfige ist auf unserer langjährigen Erfahrung basiert. So sind die Käfige u. a. oben offen und unten geschlossen, und die Seiten bestehen aus dem patentierten DUPLEX-Material, das bei einer Explosion bis zu 70 % Dehnung zulässt und die Druckwelle bricht.

Die Sicherheits-Befüllkäfige sind in verschiedenen Größen und Konstruktionen sowie mit verschiedenen Formen von Zusatzausrüstung erhältlich.

## GABBIE DI GONFIAGGIO DI SICUREZZA

Le gabbie di gonfiaggio di sicurezza rappresentano un elemento fondamentale della nostra gamma prodotti. Le gabbie di gonfiaggio sono state progettate per proteggere il montatore durante il gonfiaggio degli pneumatici di autocarri, bus e ruote di grandi dimensioni di veicoli fuoristrada.

La costruzione delle nostre gabbie si basa sulla nostra esperienza pluriennale. Le gabbie sono aperte nella parte superiore e chiuse in quella inferiore, i lati sono in materiale brevettato DUPLEX che consente un allungamento fino al 70% e interrompe la pressione dell'aria in caso di esplosione.

Le gabbie di gonfiaggio di sicurezza sono disponibili in diverse misure e design, oltre a differenti accessori.



## TBR ALCATRAZ

TBR ALCATRAZ is a safety inflation cage, that is of a basic design.

The safety inflation cage is made of simplex wire mesh which is a single layer of expanded metal.

The safety inflation cage is fitted with a front door and can be fitted with Michelin inflating gauge or PCI 900 computer inflator.

TBR ALCATRAZ offers safe inflation at the cost of a small investment.



## TBR ALCATRAZ

TBR ALCATRAZ ist ein Sicherheits-Befüllkäfig, der von Design sehr einfach ist.

Der Sicherheits-Befüllkäfig ist aus Simplex-Drahtgeflecht gefertigt, das aus einschichtigem Streckmetall besteht.

Der Sicherheits-Befüllkäfig ist mit Vordertür und kann mit Michelin-Pumpenuhr oder PCI 900 Befüllcomputer montiert werden.

Mit TBR ALCATRAZ erhält man sicheres Aufpumpen bei minimaler Investition.

## TBR ALCATRAZ

TBR ALCATRAZ è una gabbia di gonfiaggio di sicurezza con design di base.

La gabbia di gonfiaggio è realizzata in rete metallica simplex, ovvero un singolo strato di metallo espanso.

La gabbia di gonfiaggio è provvista di un portello anteriore e può essere utilizzata con il manometro Michelin o con il dispositivo di gonfiaggio computerizzato PCI 900.

TBR ALCATRAZ assicura un gonfiaggio sicuro con un piccolo investimento.

### COLOURS



7016

### VEHICLE



TRUCK

### SIMPLEX



### MAX WHEEL SIZE



H: 1.150 MM/45.3"  
W: 550 MM/21.6"

MODEL	ITEM NO.	DIMENSIONS (H) X (W) X (L)
TBR ALCATRAZ, SIMPLEX	0-51110601/00	1.248 MM (H) X 680 MM (W) X 1.260 MM (L) / 49.2" (H) X 26.7" (W) X 49.6" (L)

### OPTIONS / ZUBEHÖR / OPTIONAL //INCL. INSTALLATION

<input type="checkbox"/>	PCI 900/12 BAR COMPUTER INFLATOR KIT	0-51110701/00
<input type="checkbox"/>	MICHELIN INFLATION SET	0-51110801/00
<input type="checkbox"/>	SPECIAL RAL COLOURS, CODE	XXXX



PCI 900 computer inflator



MICHELIN  
inflation set



### TBR 1100

TBR 1100 DUPLEX is the newest version of safety inflation cages for truck wheels.

TBR 1100 is made of modules for composition of a cage with specific needs.

TBR 1100 is made to meet all the individual needs of an advanced workshop and ensuring first-class safety.

### TBR 1100

TBR 1100 DUPLEX ist die neueste Version der Sicherheitsbefüllkäfige für LKW-Räder.

TBR 1100 besteht aus Modulen zur Erstellung eines Käfigs mit exakten Ansprüchen.

TBR 1100 erfüllt alle individuellen Anforderungen einer modernen Werkstatt mit Reifenwechsel und sichert gleichzeitig ein hohes Sicherheitsniveau.

### TBR 1100

TBR 1100 DUPLEX è l'ultima versione delle gabbie di gonfiaggio di sicurezza per le ruote di autocarri.

TBR 1100 ha una struttura modulare per consentire la composizione di una gabbia in base a specifiche esigenze.

TBR 1100 è stata creata per soddisfare tutte le singole esigenze di un'officina all'avanguardia e per garantire un elevato livello di sicurezza.



2 X TBR 1100 with connection set



Roll-Out System



Omega Jet System

#### COLOURS



7016

#### VEHICLE



TRUCK

#### DUPLEX



#### MAX WHEEL SIZE



H: 1.300 MM/51.2"  
W: 600 MM/23.6"

MODEL	ITEM NO.	DIMENSIONS (H) X (W) X (L)
TBR 1100, DUPLEX	0-51110901/00	1.420 MM (H) X 800 MM (W) X 1.450 MM (L) / 55.9" (H) X 31.5" (W) X 57.1"

OPTIONS / ZUBEHÖR / OPTIONAL INCL. INSTALLATION		OPTIONS / ZUBEHÖR / OPTIONAL INCL. INSTALLATION			
<input type="checkbox"/>	ROLL-OUT SYSTEM, FRONT*	0-51111001/00	<input type="checkbox"/>	PCI 900/12 BAR COMPUTER INFLATOR KIT	0-51117001/00
<input type="checkbox"/>	ROLL-OUT SYSTEM, BACK*	0-51111101/00	<input type="checkbox"/>	PCI 1200/12 BAR COMPUTER INFLATOR KIT	0-51111601/00
<input type="checkbox"/>	BACKDOOR	0-51112001/00	<input type="checkbox"/>	OMEGA JET SYSTEM, PNEUMATIC**	0-51119001/00
<input type="checkbox"/>	SLIDING DOOR, LEFT SIDE	0-51113001/00	<input type="checkbox"/>	EMERGENCY EMPTYING SYSTEM	0-51112101/00
<input type="checkbox"/>	SLIDING DOOR, RIGHT SIDE	0-51114001/00	<input type="checkbox"/>	WARNING LIGHT, ORANGE	0-51112201/00
<input type="checkbox"/>	CONNECTION SET, DOUBLE CAGES	0-51115001/00	<input type="checkbox"/>	AUDIBLE ALARM, SOUND AND WARNING LIGHT, RED	0-51112301/00
<input type="checkbox"/>	MICHELIN MANUAL INFLATOR KIT	0-51116001/00	<input type="checkbox"/>	SPECIAL RAL COLOURS, CODE	XXXX

\*Only one roll-out system is possible per cage

\*\*Only together with PCI 1200 Computer Inflator



## OTR 2000

OTR 2000 is suitable for the inflation of truck- and OTR wheels.

The inflation cage is available as a basic version, mountable with various equipment - including a side door, easing the access to the pump nipple and wheel inspection.

All versions of OTR 2000 are only manufactured and delivered as DUPLEX.

## OTR 2000

Der OTR 2000 ist für das Befüllen von Traktoren-, EM- und LKW-Reifen geeignet.

Der Befüllkäfig ist als Basismodell verfügbar und kann mit unterschiedlicher Ausrüstung montiert werden – darunter u.a. eine Seitenklappe, die den Zugang zum Pumpennippel und die Inspektion der Reifen erleichtert.

Alle Versionen von OTR 2000 werden nur als DUPLEX produziert und geliefert.

## OTR 2000

OTR 2000 è una gabbia di gonfiaggio di sicurezza adatta al gonfiaggio di pneumatici di autocarro e OTR.

La gabbia di gonfiaggio è disponibile in versione base, con la possibilità di montaggio di diverse attrezzature, presenta una porta laterale che facilita l'accesso al nipplo della pompa e l'ispezione delle ruote.

Tutte le versioni di OTR 2000 sono prodotte e consegnate solamente come DUPLEX.

**NEW  
STREAMLINED  
SAFETY  
INFLATION  
CAGE**



OTR 2000 seen from the side.

### COLOURS



7016

### VEHICLE



OTR



EM



TRUCK

### DUPLEX



### MAX WHEEL SIZE



H: 1.850 MM/72.8"  
W: 850 MM/33.5"

MODEL	ITEM NO.	DIMENSIONS (H) X (W) X (L)
OTR 2000, CAGE ONLY, DUPLEX	0-51120301/00	2.004 MM (H) X 1.050 MM (B) X 2.164 MM (L) / 78.9" (H) X 41.3" (W) X 85.2" (L)



Roll-out system.

OPTIONS / ZUBEHÖR / OPTIONAL // INCL. INSTALLATION	ITEM NO.
<input type="checkbox"/> PCI 1200 COMPUTER INFLATOR KIT	0-51111801/00
<input type="checkbox"/> MICHELIN MANUAL INFLATOR KIT	0-51116001/00
<input type="checkbox"/> ROLL-OUT SYSTEM	0-51120401/00
<input type="checkbox"/> SLIDING DOOR, LEFT SIDE	0-51120501/00
<input type="checkbox"/> EMERGENCY EMPTYING SYSTEM	0-51112101/00
<input type="checkbox"/> WARNING LIGHT, ORANGE	0-51112201/00
<input type="checkbox"/> AUDIBLE ALARM, SOUND AND WARNING LIGHT	0-51112301/00
<input type="checkbox"/> SPECIAL RAL COLOURS, CODE	XXXX



## MAXI SAFE

Safety inflation cage for the largest of tyres. This cage has a double door in front and a sliding door on the left side. Option to purchase a PCI 1200 computer inflator for 12 bar and door switches.

## MAXI SAFE

Sicherheits-Befüllkäfig zum Aufpumpen von sehr großen Reifen. Dieser Käfig ist mit Doppeltüren vorne und einer Rolltür auf der linken Seite ausgestattet. PCI 1200 Befüllcomputer für 12 Bar inkl. Türkontakte gegen Aufpreis erhältlich.

## MAXI SAFE

Gabbia di gonfiaggio di sicurezza per le ruote di diametro importante. Questa gabbia ha una doppia porta anteriore e una porta scorrevole sul lato sinistro. Possibilità di acquistare un dispositivo di gonfiaggio computerizzato ad alta portata PCI 1200 da 12 bar e interruttori porte.

### COLOURS



7016

### VEHICLE



OTR

EM

TRUCK

### DUPLEX



### MAX WHEEL SIZE



H: 2.200 MM/86.6"  
W: 1.200 MM/47.2"

MODEL	ITEM NO.	DIMENSIONS (H) X (W) X (L)
MAXI SAFE, CAGE ONLY, DUPLEX	0-51113301/00	2.400 MM (H) X 1.400 MM (W) X 2.400 MM (L) / 94.5" (H) X 55.1" (W) X 94.5" (L)

OPTIONS / ZUBEHÖR / OPTIONAL //INCL. INSTALLATION	ITEM NO.
<input type="checkbox"/> PCI 1200, 12 BAR COMPUTER INFLATOR KIT	0-51111701/00
<input type="checkbox"/> EMERGENCY EMPTYING SYSTEM	0-51112101/00
<input type="checkbox"/> SIDE SUPPORT FOR WHEEL	0-51113901/00

MADE IN DENMARK



# COMPUTER INFLATORS

## COMPUTER INFLATORS

Our computer inflators are designed with a view to high quality, precision and long service life. The inflation computers are designed in Denmark and manufactured and tested in our own workshop. They are made up of high-quality components from Danish suppliers, and the internal software is updated and maintained based on customer requests and requirements relating to the standards applicable to this product group.

### DISPLAY

The computer inflators have a clear display and are easy to operate so that wheels are filled with the correct amount of air.

## BEFÜLLCOMPUTER

Unsere Befüllcomputer werden im Hinblick auf hohe Qualität, Genauigkeit und lange Lebensdauer entwickelt. Die Befüllcomputer werden in Dänemark entwickelt und gefertigt und in der eigenen Werkstatt getestet. Sie bestehen aus qualitativ hochwertigen Komponenten dänischer Zulieferer, und die interne Software wird von Kundenwünschen und Anforderungen nach Standards dieser Produktgruppe ausgehend aktualisiert und gepflegt.

### DISPLAY

Die Befüllcomputer sind mit einem übersichtlichen Display ausgestattet und lassen sich leicht bedienen, sodass Räder mit der korrekten Luftmenge befüllt werden.

## DISPOSITIVI DI GONFIAGGIO COMPUTERIZZATI

I nostri dispositivi di gonfiaggio computerizzati sono stati progettati per garantire qualità, precisione e lunga durata. I computer di gonfiaggio sono stati progettati in Danimarca e costruiti e testati nella nostra officina interna. Sono costituiti da componenti di alta qualità di fornitura danese e il software interno viene aggiornato e mantenuto in base alle richieste dei clienti e ai requisiti imposti dalle normative applicabili a questo gruppo di prodotti.

### VISUALIZZATORE

I dispositivi di gonfiaggio computerizzati sono dotati di un visualizzatore chiaro e sono di facile funzionamento, garantendo che la corretta quantità di aria venga immessa negli pneumatici.







## PCI 900 COMPUTER INFLATOR

Fully automatic computer inflator. Fast and simple operation. Available in 7 and 12 Bar version. 3 programs for different settings for overpressure. Approved for nitrogen inflation.

### COLOURS



7016

## PCI 900 BEFÜLLCOMPUTER

Vollautomatischer Befüllcomputer. Einfache und schnelle Bedienung. In 7- und 12-bar-Ausführung lieferbar. 3 Programme für unterschiedliche Einstellungen von Überdruck. Für das Befüllen mit Stickstoff zugelassen.

### VEHICLE



## DISPOSITIVO DI GONFIAGGIO COMPUTERIZZATO PCI 900

Dispositivo di gonfiaggio computerizzato completamente automatico. Semplice e veloce. Disponibile in versione da 7 e 12 Bar. 3 programmi per l'impostazione della sovrappressione. Approvato per il gonfiaggio con azoto.

MODEL	MEASUREMENT UNITS	ITEM NO.	POWER CONNECTION
PCI 900, 7 BAR	0.1 BAR/1 PSI/5 KPA	0-51105901/00	230V (+/- 10%) - 50/60 HZ
PCI 900, 12 BAR	0.1 BAR/1 PSI/5 KPA	0-51106001/00	230V (+/- 10%) - 50/60 HZ



## PCI 1200 COMPUTER INFLATOR

Fully automatic computer inflator available in 7 and 12 Bar versions. The PCI 1200 has a wide range of features among others short processing time, easy operation, increased lifespan and great measurement accuracy. Approved for nitrogen inflation and prepared for the Jet System.

### COLOURS



7016

## PCI 1200 BEFÜLLCOMPUTER

Vollautomatischer Befüllcomputer, der in 7- und 12-bar-Ausführungen lieferbar ist. PCI 1200 hat viele Eigenschaften z.B. geringer Prozessdauer, einfacher Bedienung, erhöhter Lebensdauer und hoher Messgenauigkeit. Für das Befüllen mit Stickstoff zugelassen und für das Jet System vorbereitet.

### VEHICLE



## DISPOSITIVO DI GONFIAGGIO COMPUTERIZZATO PCI 1200

Dispositivo di gonfiaggio computerizzato completamente automatico disponibile nelle versioni da 7 e 12 Bar. PCI 1200 offre una vasta gamma di funzioni tra cui: breve tempo di elaborazione, funzionamento semplice, maggiore vita utile e grande precisione di misurazione. Approvato per il gonfiaggio con azoto e predisposto per il Sistema Jet AHCON.

MODEL	MEASUREMENT UNITS	ITEM NO.	POWER CONNECTION
PCI 1200, 7 BAR	BAR/PSI/KPA	0-51111401/00	230V (+/- 10%) - 50/60 HZ
PCI 1200, 12 BAR	BAR/PSI/KPA	0-51111501/00	230V (+/- 10%) - 50/60 HZ

OPTIONS / ZUBEHÖR / OPTIONAL	ITEM NO.	FITS
PCI HOLDER	0-51106901/00	PCI 900/PCI 1200 ON IT200 AND TBR ALCATRAZ
PCI HOLDER	0-51111901/00	PCI 1200 ON TBR 1100
PCI HOLDER	0-51120001/00	PCI 1200 ON OTR 2000 AND MAXI SAFE
BRACKET FOR WALL MOUNTING	0-51120201/00	PCI 900 AND PCI 1200
FLOOR STAND	0-51107201/00	PCI 900 AND PCI 1200
NITROGEN REGULATOR	0-51107301/00	3-WAY REGULATOR FOR NITROGEN/AIR

# TYRE SPREADER

## TYRE SPREADER

We have designed 2 types of tyre spreaders for easy, ergonomic and safe inspection and repair of tyres. One version is for passenger cars and the other - for truck, tractor and industrial tyres.

Common to both tyre spreader models is that they provide optimum working height thanks to which both knees and back are protected at work.

The model for large wheels (TS 9000) is designed with a very user-friendly lifting device and an integrated halogen lamp, which makes it easy to inspect the tyre and localise any damages thanks to its bright light.

## REIFENSPREIZER

Für die einfache, ergonomische und sichere Inspektion und Reparatur von Reifen haben wir zwei Arten von Reifenspreizern entwickelt: eine Variante für PKW-Reifen und eine Variante für LKW-, Traktor- und Industriereifen.

Den beiden Ausführungen der Reifenspreizern ist gemein, dass sie eine optimale Arbeitshöhe sichern, wodurch sowohl Knie als auch Rücken bei der Arbeit geschont werden.

Das Modell für größere Räder (TS 9000) ist mit einer sehr benutzerfreundlichen Hebevorrichtung sowie einer integrierten Halogenlampe versehen, die mit ihrem hellen Licht die Inspektion des Reifens und Lokalisierung eventueller Schäden vereinfacht.

## ESPANSORE PER PNEUMATICI

Abbiamo progettato 2 tipi di espansori per pneumatici per una facile, ergonomica e sicura ispezione e riparazione degli pneumatici. Una versione è per le auto, mentre l'altra per autocarri, trattori e veicoli industriali.

Entrambi gli espansori offrono un'altezza di lavoro ottimale che protegge ginocchia e schiena durante il lavoro.

Il modello per ruote di grandi dimensioni (TS 9000) è stato progettato con un dispositivo di sollevamento semplice e lampada alogena integrata, che consente una facile ispezione dello pneumatico e la localizzazione di eventuali danni grazie alla luce emessa.





## TYRE SPREADER TS 9000

For inspection- and repair-work of truck-, tractor- and EM-tyres. Including 12 V halogen light. Pneumatic raising and lowering function. Working height: 895 mm.

### COLOURS



7016

## REIFENSPREIZER TS 9000

Für Inspektion- und Reparaturarbeit an LKW-, Traktor- und EM-Reifen. 12 V Halogen Beleuchtung. Pneumatische Hub- und Senkfunktion. Arbeitshöhe: 895 mm.

### VEHICLE



TRUCK OTR

## ESPANSORE PER PNEUMATICI TS 9000

Per l'ispezione e la riparazione di pneumatici per autocarri, trattori e macchine movimento terra. Lampada alogena da 12 V compresa. Funzione pneumatica di sollevamento e abbassamento. Altezza di lavoro: 895 mm.

### MAX LOAD



350 KG/771.6 LBS

MODEL	ITEM NO.	DIMENSIONS (H) X (W) X (L)
TS 9000	0-51114801/00	1.000 MM (H) X 1.200 MM (W) X 1.200 MM (L) / 39.4" (H) X 47.2" (W) X 47.2" (L)



## TYRE SPREADER TS 700

For inspection and repair of passenger car tyres and commercial car tyres. Adjustable inspection lamp can be purchased separately.

### COLOURS



7016

## REIFENSPREIZER TS 700

Für Reifen Inspektion und Reparatur von Reifen. Eine justierbare Inspektionslampe kann hinzugekauft werden.

### VEHICLE



CAR VAN 4X4

## ESPANSORE PER PNEUMATICI TS 700

Per ispezione e riparazione di pneumatici per auto e veicoli commerciali. La lampada regolabile può essere acquistata separatamente.

### MAX LOAD



65 KG/143 LBS

MODEL	ITEM NO.	DIMENSIONS (H) X (W) X (L)
TS 700	0-51114901/00	1.000 MM (H) X 250 MM (W) X 850 MM (L) / 39.4" (H) X 9.8" (W) X 33.5" (L)
INSPECTION LAMP	0-51115301/00	25W halogen



NEXION SPA - ITALY -

[info@mondolfoferro.it](mailto:info@mondolfoferro.it) - [www.mondolfoferro.it](http://www.mondolfoferro.it)

*The company reserves the right to modify the technical specifications of its products at any time* 07\_2019.