

**EXPORT EQUIPMENT CATALOGUE**

# **WHEEL BALANCERS AND ORIGINAL ACCESSORIES EFFECTIVE FROM JANUARY 2024**



automotive service equipment

**REL. MARCH 2024**

Nexion SpA reserves the right to change the specifications of its products at any time without prior notice. The company declines all responsibility in the event of claims deriving from the use of non-original accessories or spare parts with consequent forfeiture of the EC declaration of conformity.

# MONDOLFO FERRO

# SUMMARY

<b>CAR WHEEL BALANCERS</b>	<b>4</b>
MT3100UP - MT3200UP - MT3200UP PLUS	4
MT3200 C UP PLUS	5
MT3600UP	6
MT3600UP C	7
MT3350UP - MT3350CUP	8
MT3650UP - MT3650CUP	9
MT3650 UP TOUCHSCREEN - MT3650C UP TOUCHSCREEN	10
MT3500 UP - MT3500C UP LASER	11
MT3800 UP - MT3800C UP LASER	12
MT3800 UP - MT3800C UP TOUCHSCREEN	13
MT3900C UP LASER SCAN AUTOMATIC LOCKING	14
MT4000C UP DIAGNOSTIC	15
ACCESSORIES FOR CAR WHEEL BALANCERS	16
ACCESSORIES FOR WHEEL BALANCERS FOR MOTORBIKE	35
ACCESSORIES FOR MOTORBIKES WHEEL BALANCERS	36
<b>WHEEL BALANCERS FOR "CAR MOBILE SERVICE"</b>	<b>39</b>
MT3000 UP - TILT UP HAND SPIN	39
MT3000 UP VAN MOTORIZED SPIN	40
MT3000 UP WORKBENCH HAND SPIN	41
ACCESSORIES WHEEL BALANCERS FOR "CAR MOBILE SERVICE"	42
<b>WHEEL BALANCERS FOR "TRUCK MOBILE SERVICE"</b>	<b>44</b>
MT6310 MOBILE TRUCK	44
<b>TRUCK WHEEL BALANCERS</b>	<b>46</b>
MT2450 EASY-ALU	46
MT2650 EASY-ALU	47
MT6350	48
ACCESSORIES FOR TRUCK WHEEL BALANCERS	49

# CAR WHEEL BALANCERS

## MT3100UP - MT3200UP - MT3200UP PLUS

### STANDARD ACCESSORIES

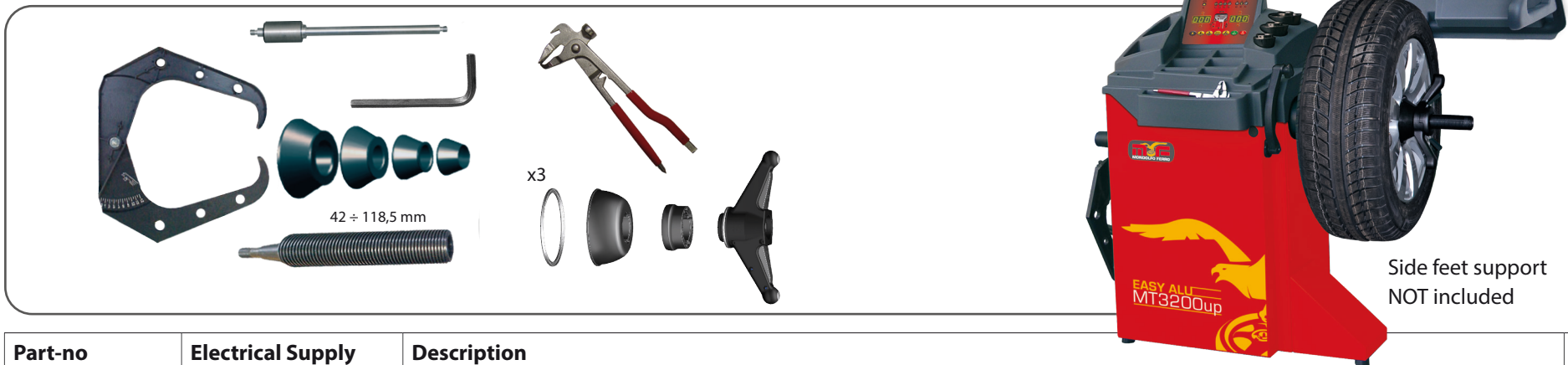

Part-no	Electrical Supply	Description
0-21331000/16	200÷230V/1Ph/50Hz	<b>MT3100up</b> - LCD display machine with manual data input and automatic brake at the end of the spin (wheel guard included).
0-21331001/16	110÷115V/1Ph/60Hz	As above, <b>different power supply</b> .
0-21331002/16	200÷230V/1Ph/50Hz	<b>MT3100up</b> - LCD display machine with manual data input and automatic brake at the end of the spin (wheel guard NOT included)
0-21331003/16	110÷115V/1Ph/60Hz	As above, <b>different power supply</b>
0-21332000/16	200÷230V/1Ph/50Hz	<b>MT3200up</b> - LCD display machine with automatic data input and automatic brake at the end of the spin (wheel guard included).
0-21332001/16	110÷115V/1Ph/60Hz	As above, <b>different power supply</b> .
0-21332002/16	200÷230V/1Ph/50Hz	<b>MT3200up</b> - LCD display machine with automatic data input and automatic brake at the end of the spin (wheel guard NOT included).
0-21332003/16	110÷115V/1Ph/60Hz	As above, <b>different power supply</b> .
0-21332004/16	200÷230V/1Ph/50Hz	<b>MT3200up PLUS</b> - LCD display machine with automatic data input and automatic brake at the end of the spin, electrical brake & RPA (wheel guard included).
0-21332005/16	110÷115V/1Ph/60Hz	As above, <b>different power supply</b> .
0-21332006/16	200÷230V/1Ph/50Hz	<b>MT3200up PLUS</b> - LCD display machine with automatic data input and automatic brake at the end of the spin, electrical brake & RPA (wheel guard NOT included).
0-21332007/16	110÷115V/1Ph/60Hz	As above, <b>different power supply</b> .

# CAR WHEEL BALANCERS

## MT3200 C UP PLUS

### STANDARD ACCESSORIES



Side feet support  
NOT included

Part-no	Electrical Supply	Description	
0-21332008/16	200-230V/1Ph/50-60Hz	<b>MT3200-C UP PLUS</b> LCD display wheel balancer with automatic data input and automatic brake at the end of the spin, automatic wheel clamping, AWC Auto Width Calculation, automatic brake at the end of the measurement and RPA system	
0-21332009/16	100-115V/1Ph/50-60Hz	As above, but with <b>different power supply</b>	

# CAR WHEEL BALANCERS

## MT3600UP

### STANDARD ACCESSORIES

Monitor not included



Side feet support  
NOT included



Part-no	Electrical Supply	Description	
0-21336000/16	200÷230V/1Ph/50Hz	<b>MT3600up</b> - Machine with automatic data input, automatic brake at the end of the spin, RPA system; Easy Weight program (monitor NOT included).	
0-21336001/16	110÷115V/1Ph/60Hz	As above, but with <b>different power supply</b> .	
0-21336002/16	200÷230V/1Ph/50Hz	<b>MT3600up</b> - Machine with automatic data input, automatic brake at the end of the spin, RPA system (monitor and wheel guard NOT included), Easy Weight program.	
0-21336003/16	110÷115V/1Ph/60Hz	As above, but with <b>different power supply</b> .	

# CAR WHEEL BALANCERS

## MT3600UP C

### STANDARD ACCESSORIES



Monitor and pl50 not included

Part-no	Electrical Supply	Description
0-21336004/16	200-230V/1Ph/50Hz	<b>MT3600up C</b> - Wheel balancer, compact and essential with professional performances; Pneumatic wheel clamping (patent). Easy & Quick to use; Automatic wheel distance and diameter acquisition with AUTOSELECT for the automatic identification of the best balancing program;AWC (Auto Width Calculation): automatic calculation of the width even if the TL-3 external sensor is not present. The wheel balancer calculates the width by reducing the operational time;Automatic braking at end of measurement; Rpa system - research of the weight automation position and automatic clamping brake;Quick optimise, Hidden weight and Split weight programmes for motorcycles; 4 cones (42÷118,5mm); Monitor and PL50 not included
0-21336005/16	110÷115V/1Ph/50-60Hz	As above, but with <b>different power supply.</b>

# CAR WHEEL BALANCERS

## MT3350UP - MT3350CUP

### STANDARD ACCESSORIES

#### Manual wheel clamping



### STANDARD ACCESSORIES

#### Automatic wheel clamping (C Version)

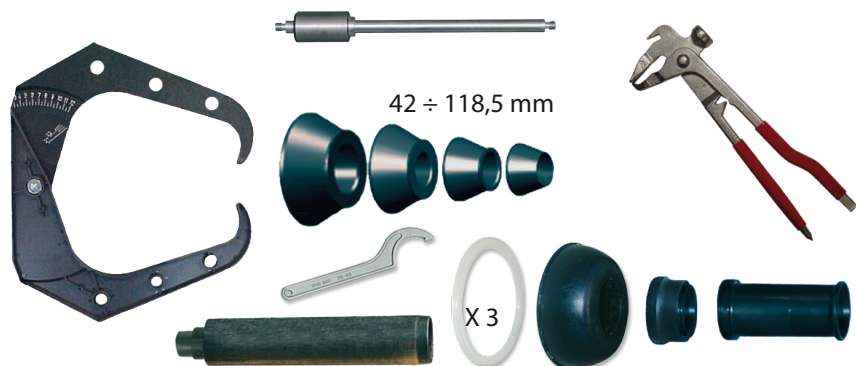

Part-no	Electrical Supply	Description
0-21333500/16	200÷230V/1Ph/50Hz	<b>MT3350 UP</b> - Professional wheel balancer for cars, lightweight transport vehicles and motor vehicles; double display control panel; Laser, spotlight, speed and ease of use; automatic data acquisition, electrical brake, laser & LED, wheel guard
0-21333501/16	110÷115V/1Ph/60Hz	As above, but with <b>different power supply</b> .
0-21333502/16	200÷230V/1Ph/50Hz	<b>MT3350-C UP</b> - Professional wheel balancer for cars, lightweight transport vehicles and motor vehicles; new automatic wheel clamping system; double display control panel; Laser, spotlight, speed and ease of use; automatic data acquisition, electrical brake, laser & LED, wheel guard
0-21333503/16	110÷115V/1Ph/60Hz	As above, but with <b>different power supply</b> .



# CAR WHEEL BALANCERS

## MT3650UP - MT3650CUP

### STANDARD ACCESSORIES

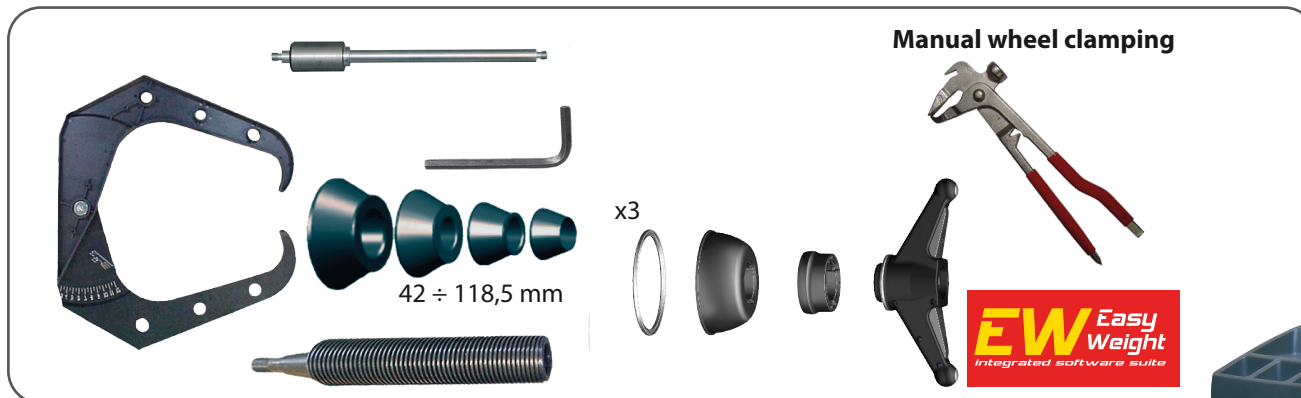

### STANDARD ACCESSORIES

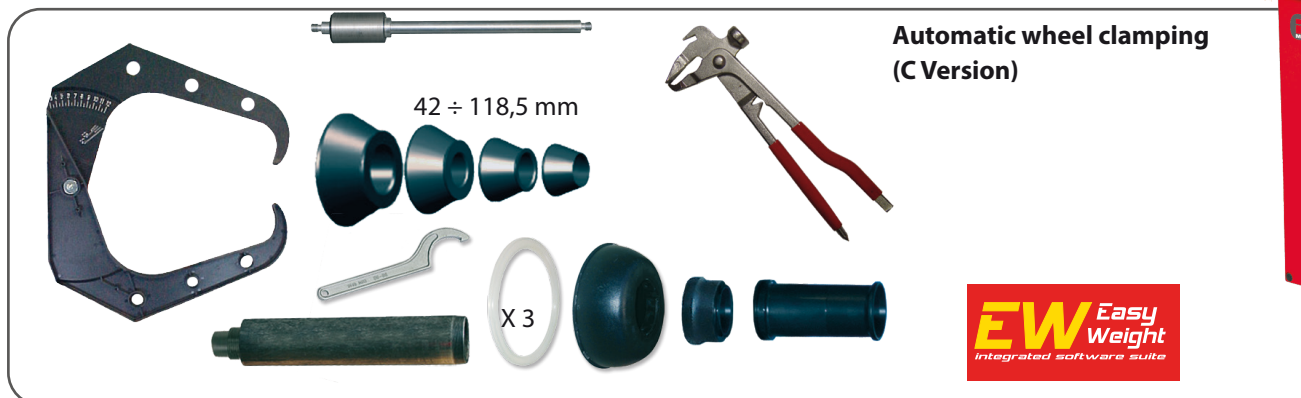

Monitor not included



Part-no	Electrical Supply	Description
0-21336500/16	200÷230V/1Ph/50Hz	<b>MT3650 up</b> - Machine with LaserLine indicator, automatic data input (monitor NOT included), Easy Weight program.
0-21336501/16	110÷115V/1Ph/60Hz	As above, but with <b>different power supply</b> .
0-21336502/16	200÷230V/1Ph/50Hz	<b>MT3650C up</b> - Machine with automatic wheel clamping, LaserLine indicator, automatic data input , Easy Weight program (monitor NOT included).
0-21336503/16	110÷115V/1Ph/60Hz	As above, but with <b>different power supply</b> .

# CAR WHEEL BALANCERS

## MT3650 UP TOUCHSCREEN - MT3650C UP TOUCHSCREEN

### STANDARD ACCESSORIES



### STANDARD ACCESSORIES

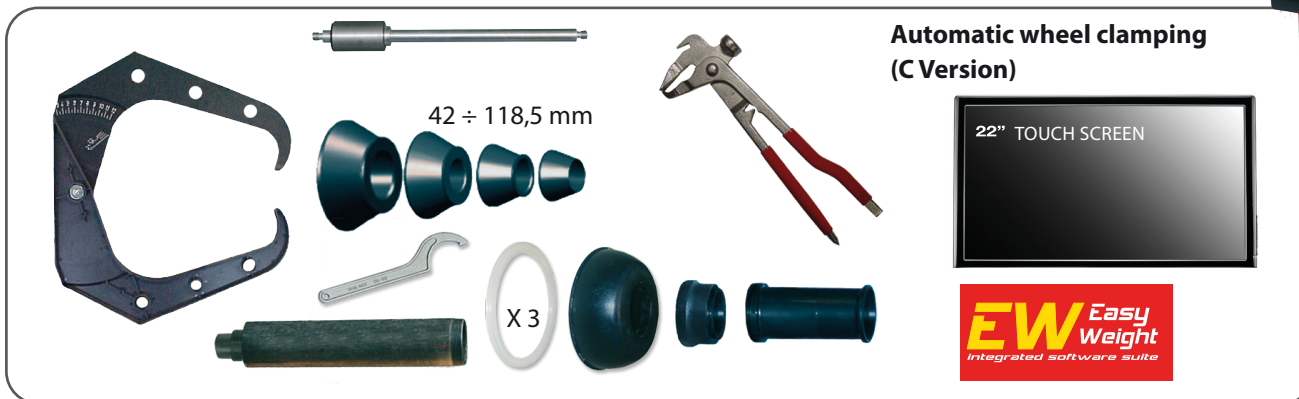

Part-no	Electrical Supply	Description
0-21336504/16	200÷230V/1Ph/50Hz	<b>MT3650 up Touchscreen</b> - Machine with manual wheel clamping, LaserLine indicator, automatic data input, electronic braking and automatic positioning, Easy Weight program. TL3 for touchless width measurement NOT included.
0-21336505/16	200÷230V/1Ph/50Hz	<b>MT3650C up Touchscreen</b> - Machine with automatic wheel clamping, LaserLine indicator, automatic data input, electronic braking and automatic positioning, Easy Weight program. TL3 for touchless width measurement NOT included.

# CAR WHEEL BALANCERS

## MT3500 UP - MT3500C UP LASER

### STANDARD ACCESSORIES

#### Manual wheel clamping

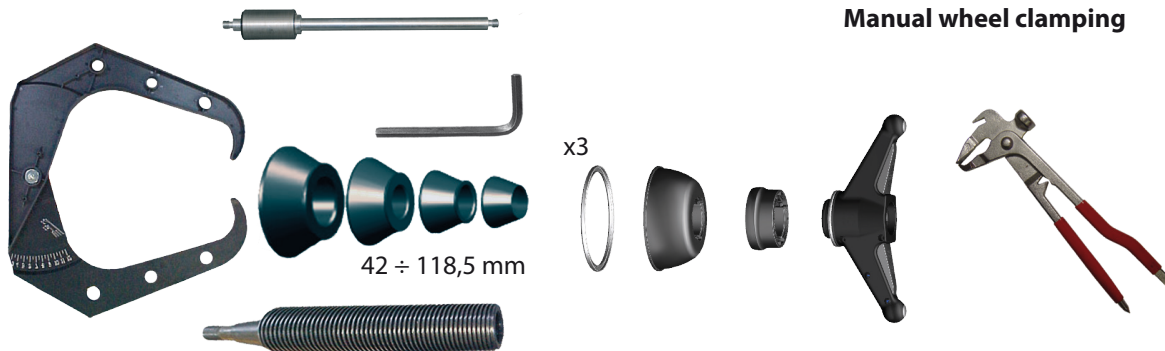

### STANDARD ACCESSORIES

#### Automatic wheel clamping (C Version)

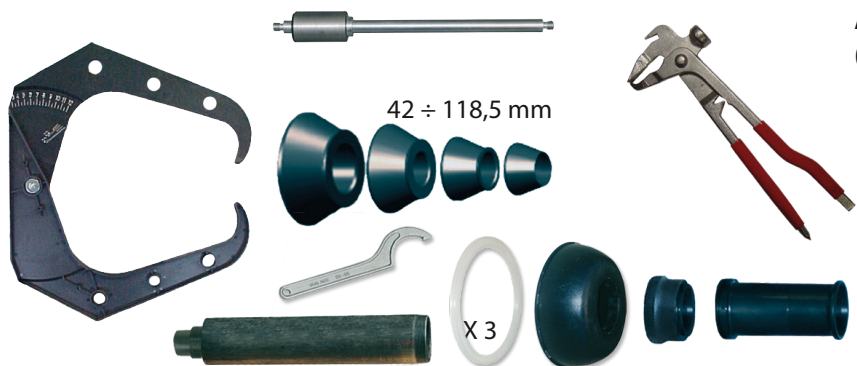

MT3500 up Version

Part-no	Electrical Supply	Description
0-21335006/16	100-230V/1Ph/50-60Hz	<b>MT3500C up Laser</b> High performance wheel balancer with LCD Display and LaserLine indicator, automatic wheel clamping, automatic data input with Auto Select Program, "Zero Space" wheel guard (automatic sensor not included )
0-21335007/16	100-230V/1Ph/50-60Hz	<b>MT3500 up Laser</b> - As above but <b>with manual wheel clamping</b> .

# CAR WHEEL BALANCERS

## MT3800 UP - MT3800C UP LASER

### STANDARD ACCESSORIES

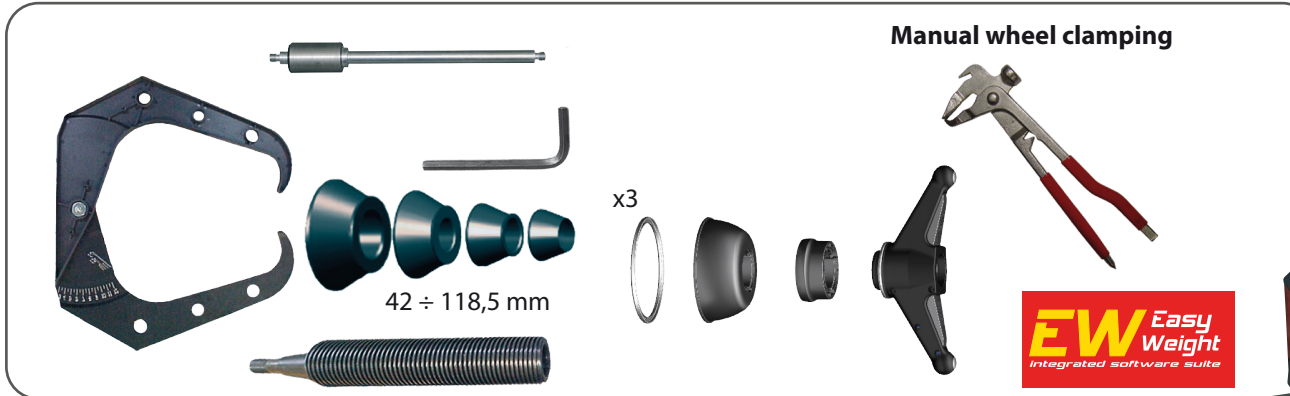

### STANDARD ACCESSORIES



Part-no	Electrical Supply	Description	
0-21338006/16	100-230V/1Ph/50-60Hz	<b>MT3800C up Laser</b> - High performance wheel balancer with LaserLine indicator, automatic wheel clamping, automatic data input with Auto Select Program, "Zero Space" wheel guard (monitor and automatic sensor not included )	
0-21338007/16	100-230V/1Ph/50-60Hz	<b>MT3800 up Laser</b> - As above but with manual wheel clamping.	

# CAR WHEEL BALANCERS

## MT3800 UP - MT3800C UP TOUCHSCREEN

### STANDARD ACCESSORIES



Monitor included

### STANDARD ACCESSORIES



MT3800 up C Version

Part-no	Electrical Supply	Description
0-21338011/16	100-230V/1Ph/50-60Hz	<b>MT3800C up Touchscreen</b> - Wheel balancer with 22" industrial Touchscreen monitor, Laser Line system, Led illuminator, AUTOSELECT UP device for automatic program selection, LaserPlane function, exclusive Wireless locking device (WINUT), automatic wheel clamping, space saving wheel guard, Easy Weight program included (Sonar and Run-Out kit NOT included)
0-21338010/16	100-230V/1Ph/50-60Hz	<b>MT3800 up Touchscreen</b> - As above but with manual wheel clamping.

# CAR WHEEL BALANCERS

## MT3900C UP LASER SCAN AUTOMATIC LOCKING

### STANDARD ACCESSORIES



Monitor included

Part-no	Electrical Supply	Description
0-21339000/16	100-230V/1Ph/50-60Hz	<b>MT3900C UP laser scan Automatic locking</b> Touch screen machine for tyre assistance centres, dealerships, workshops and car manufacturers dealing with large volumes; no-contact data input (LASER-SONAR compined system) ; 22" touchscreen monitor ; automatic electromechanical wheel clamping system; Easy Weight program included; Zero-Space wheel guard; punctiform laser.

# CAR WHEEL BALANCERS

## MT4000C UP DIAGNOSTIC

### STANDARD ACCESSORIES



### Automatic wheel clamping

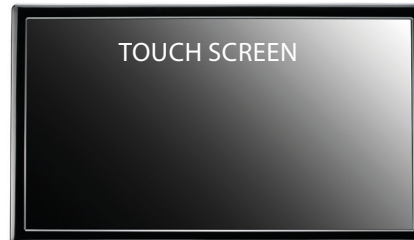

Monitor incluso

Part-no	Electrical Supply	Description	
0-21340010/16	100-230V/1Ph/50-60Hz	<b>MT4000C up diagnostic</b> Automatic wheel balancer; 22" touchscreen monitor; Laser pointer; automatic data acquisition; automatic wheel clamping; automatic braking at the end of measurement; Zero-Space wheel guard; Easy Weight program included.	







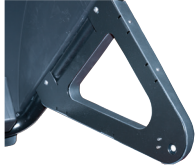
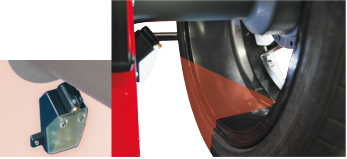
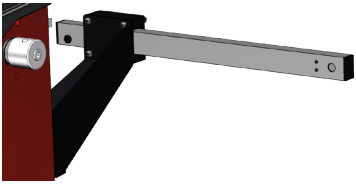





# ACCESSORIES FOR CAR WHEEL BALANCERS

Image	Part-no	Description	MT 3100up	MT 3200up	MT 3200up PLUS	MT 3200C up PLUS	MT 3350up	MT 3350 C up	MT 3600up	MT 3600 C up	MT 3650up	MT 3650 C up	MT 3650up Touchscr	MT 3650 C up Touchscr	MT 3500 up	MT 3500 C up	MT 3800 up	MT 3800 C up	MT 3800 up Touchscr.	MT 3800 C up Touchscr	MT 3900C UP	MT 4000 C UP	
	8-21100232	<b>TL3</b> - Sonar device for measure the width			★	★	★	★	★	★	★	★	★	★	★	★	★	★	★	★	★	□	□
	8-21100238	<b>Laser &amp; Led kit.</b>	★	★	★	★	□	□	★	★	□	□	□	□									
	8-21100277	<b>Kit RRS-2</b> , Kit Sonar Runout							★	★	★	★	★	★									





# ACCESSORIES FOR CAR WHEEL BALANCERS

Image	Part-no	Description	MT 3100up	MT 3200up	MT 3200up PLUS	MT 3200C up PLUS	MT 3350up	MT 3350 C up	MT 3600up	MT 3600 C up	MT 3650up	MT 3650 C up	MT 3650up Touchscr	MT 3650 C up Touchscr	MT 3500 up	MT 3500 C up	MT 3800 up	MT 3800 C up	MT 3800 up Touchscr.	MT 3800 C up Touchscr	MT 3900C UP	MT 4000 C UP	
<b>VARIOUS AND CUSTOMIZATION KITS</b>																							
 LAN CONNECTION KIT	8-21100255	<b>LAN CONNECTION KIT</b> Interconnection kit of the wheel balancer to the company management system network; it allow to view, archive and print remotely the different measurement and diagnostic reports of the diagnostic wheel balancer.							★	★	★	★	★	★				★	★	★	★	★	★
	8-21100253/16	<b>Support panel for HPC</b> High Precision Collets centering kit, painted in red color ( for MT3350 UP, MT3500 UP, MT3800 UP series and MT3900-C UP and MT4000-C UP painted in red color RAL 3002 in /16)													★	★	★	★	★	★	★	★	★
	8-21100253/64	<b>Support panel for HPC</b> High Precision Collets centering kit painter in dark grey ( for MT3350 UP, MT3500 UP, MT3800 UP series and MT3900-C UP anchn MT4000-C UP painted in other colors, NOT RAL 3002 in /16)													★	★	★	★	★	★	★	★	★
	8-21100159	<b>CLIP</b> - Clip for adhesive weight	★	★	★	★	★	★	★	★	★	★	★	★									
	8-21100158/16	<b>PL50</b> - Side feet support (RED COLOR)	★	★	★	★			★	★													
	8-21100158/90	<b>PL50</b> - Side feet support (BLACK COLOR)	★	★	★	★			★	★													

# ACCESSORIES FOR CAR WHEEL BALANCERS

Image	Part-no	Description	MT 3100up	MT 3200up	MT 3200up PLUS	MT 3200C up PLUS	MT 3350up	MT 3350 C up	MT 3600up	MT 3600 C up	MT 3650up	MT 3650 C up	MT 3650up Touchscr	MT 3650 C up Touchscr	MT 3500 up	MT 3500 C up	MT 3800 up	MT 3800 C up	MT 3800 up Touchscr.	MT 3800 C up Touchscr	MT 3900C UP	MT 4000 C UP	
	8-21100258/16	<b>Side support panel:</b> accessory holder support panel for centering kits and HPC kits, painted in red color (for wheel balancers already painted in red color RAL 3002 - /16)	★	★	★	★			★	★													
	8-21100258/64	<b>Side support panel:</b> accessory holder support panel for centering kits and HPC kits, painted in dark grey color (for wheel balancers already painted in other colors, NOT RAL 3002 - /16)	★	★	★	★			★	★													
	8-21100191	<b>CB - Pedal brake</b>	★	★																			
	8-21100251	<b>DISPENSER KIT:</b> easy-to-use dispenser kit for adhesive counterweights coil	★	★	★	★	★	★	★	★	★	★	★	★	★	★	★	★	★	★	★	★	★
	8-21100252	<b>Adhesive counterweights coil:</b> metal coil 5 gr x 1200 - 6 kg	★	★	★	★	★	★	★	★	★	★	★	★	★	★	★	★	★	★	★	★	★
	8-21100292/90	<b>VC - Voltage Converter 220V to 110V</b> Voltage converter to electrically connect a 110V wheel balancer to a 220V mains voltage. Only for markets that have dual 220V and 110V mains power supplies and for wheel balancers manufactured in 110V.	★	★	★	★	★	★	★	★	★	★	★	★									



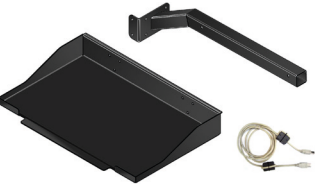

# ACCESSORIES FOR CAR WHEEL BALANCERS

Image	Part-no	Description		MT 3100up	MT 3200up	MT 3200up PLUS	MT 3200C up PLUS	MT 3350up	MT 3350 C up	MT 3600up	MT 3600 C up	MT 3650up	MT 3650 C up	MT 3650up Touchscr	MT 3650 C up Touchscr	MT 3500 up	MT 3500 C up	MT 3800 up	MT 3800 C up	MT 3800 up Touchscr.	MT 3800 C up Touchscr	MT 3900C UP	MT 4000 C UP		
<b>MONITORS AND PRINTER</b>																									
	8-21100235	19" Wide screen monitor.								★	★	★	★						★	★					
	8-21100234	22" Wide screen monitor.										★	★						★	★					
	8-21120006	Cleaning kit for monitor								★	★	★	★	★	★				★	★	★	★	★	★	★
	8-21120005	USB inkjet printer unit																			★	★	★	★	
	8-21200002/90	Printer support kit																			★	★	★	★	

# ACCESSORIES FOR CAR WHEEL BALANCERS

Image	Part-no	Description	MT 3100up	MT 3200up	MT 3200up PLUS	MT 3200C up PLUS	MT 3350up	MT 3350 C up	MT 3600up	MT 3600 C up	MT 3650up	MT 3650 C up	MT 3650up Touchscr	MT 3650 C up Touchscr	MT 3500 up	MT 3500 C up	MT 3800 up	MT 3800 C up	MT 3800 up Touchscr.	MT 3800 C up Touchscr	MT 3900C UP	MT 4000 CUP
<b>CENTERING ADAPTORS</b>																						
	8-21100289	<b>GBP40 EVO KIT</b> - Professional quick nut kit ø40x3mm:	<input type="checkbox"/>	<input type="checkbox"/>	<input type="checkbox"/>	<input type="checkbox"/>	<input type="checkbox"/>	<input type="checkbox"/>	<input type="checkbox"/>	<input type="checkbox"/>	<input type="checkbox"/>	<input type="checkbox"/>	<input type="checkbox"/>	<input type="checkbox"/>	<input type="checkbox"/>	<input type="checkbox"/>	<input type="checkbox"/>	<input type="checkbox"/>	<input type="checkbox"/>	<input type="checkbox"/>	<input type="checkbox"/>	<input type="checkbox"/>
	4-115868	PCF1 - Wheel protector for centering alloy rims																				
	4-115863	CF1 - Wheel clamping cap																				
	4-115864	CD1 - Spacer cap																				
	5-101561	GBP EVO - Quick nut																				
	4-104798	GBP1 - Clamp "R"																				
	4-104799	GBP2 - Clamp "L"																				
4-104796	GBP3 - Lever																					
	8-21100280	<b>CCK3 EVO KIT</b> - Centering cone kit ø40mm 42÷103,5mm:	<input type="checkbox"/>	<input type="checkbox"/>	<input type="checkbox"/>	<input type="checkbox"/>	<input type="checkbox"/>	<input type="checkbox"/>	<input type="checkbox"/>	<input type="checkbox"/>	<input type="checkbox"/>	<input type="checkbox"/>	<input type="checkbox"/>	<input type="checkbox"/>	<input type="checkbox"/>	<input type="checkbox"/>	<input type="checkbox"/>	<input type="checkbox"/>	<input type="checkbox"/>	<input type="checkbox"/>	<input type="checkbox"/>	<input type="checkbox"/>
	5-107970	CP1 - Small cone ø42÷68 mm																				
	5-107968	CP2 - Medium cone ø60÷87 mm																				
	5-107971	CP3 - Large cone ø83÷103 mm																				
	8-21100283	<b>MFS</b> Standard Threaded Shaft Ø40x3mm – 181,5 mm long	<input checked="" type="checkbox"/>	<input checked="" type="checkbox"/>	<input checked="" type="checkbox"/>	<input checked="" type="checkbox"/>	<input checked="" type="checkbox"/>	<input checked="" type="checkbox"/>	<input checked="" type="checkbox"/>	<input checked="" type="checkbox"/>	<input checked="" type="checkbox"/>	<input checked="" type="checkbox"/>	<input checked="" type="checkbox"/>	<input checked="" type="checkbox"/>	<input checked="" type="checkbox"/>	<input checked="" type="checkbox"/>	<input checked="" type="checkbox"/>	<input checked="" type="checkbox"/>	<input checked="" type="checkbox"/>	<input checked="" type="checkbox"/>	<input checked="" type="checkbox"/>	<input checked="" type="checkbox"/>
	8-21100193	<b>MFL</b> - XL threaded shaft ø40x3mm - 220mm long	<input checked="" type="checkbox"/>	<input checked="" type="checkbox"/>	<input checked="" type="checkbox"/>	<input checked="" type="checkbox"/>	<input checked="" type="checkbox"/>	<input checked="" type="checkbox"/>	<input checked="" type="checkbox"/>	<input checked="" type="checkbox"/>	<input checked="" type="checkbox"/>	<input checked="" type="checkbox"/>	<input checked="" type="checkbox"/>	<input checked="" type="checkbox"/>	<input checked="" type="checkbox"/>	<input checked="" type="checkbox"/>	<input checked="" type="checkbox"/>	<input checked="" type="checkbox"/>	<input checked="" type="checkbox"/>	<input checked="" type="checkbox"/>	<input checked="" type="checkbox"/>	
	8-21100285	<b>MBP40 EVO KIT</b> -Locking sleeve kit for electric or pneumatic wheel locking system:	<input type="checkbox"/>	<input type="checkbox"/>	<input type="checkbox"/>	<input type="checkbox"/>	<input type="checkbox"/>	<input type="checkbox"/>	<input type="checkbox"/>	<input type="checkbox"/>	<input type="checkbox"/>	<input type="checkbox"/>	<input type="checkbox"/>	<input type="checkbox"/>	<input type="checkbox"/>	<input type="checkbox"/>	<input type="checkbox"/>	<input type="checkbox"/>	<input type="checkbox"/>	<input type="checkbox"/>	<input type="checkbox"/>	<input type="checkbox"/>
	4-115868	PCF1 - Wheel protector for centering alloy rims																				
	4-115863	CF1 - Wheel clamping cap																				
	4-115864	CD1 - Spacer cap																				
	5-107394	QLS - Quick Locking Sleeve																				

# ACCESSORIES FOR CAR WHEEL BALANCERS

Image	Part-no	Description	MT 3100up	MT 3200up	MT 3200up PLUS	MT 3200C up PLUS	MT 3350up	MT 3350 C up	MT 3600up	MT 3600 C up	MT 3650up	MT 3650 C up	MT 3650up Touchscr	MT 3650 C up Touchscr	MT 3500 up	MT 3500 C up	MT 3800 up	MT 3800 C up	MT 3800 up Touchscr.	MT 3800 C up Touchscr	MT 3900C UP	MT 4000 C UP
<b>CENTERING ADAPTORS</b>																						
	802260682	VGBP Hand wheel for wheel fastener ring.	★	★	★		★		★		★		★		★		★		★			
	8-21100291	Kit with 2 revolving knob	★	★	★		★		★		★		★		★		★		★			
	8-21100244	HPC - High Precision Collets centering kit.	★	★	★	★	★	★	★	★	★	★	★	★	★	★	★	★	★	★	★	★
	8-21100243/90	Trolley for HPC kit.	★	★	★	★	★	★	★	★	★	★	★	★	★	★	★	★	★	★	★	★

# ACCESSORIES FOR CAR WHEEL BALANCERS

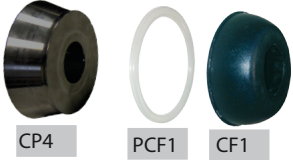
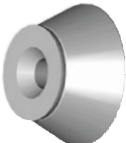

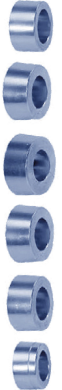
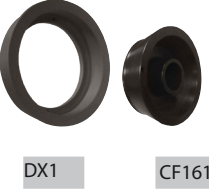

Image	Part-no	Description	MT 3100up	MT 3200up	MT 3200up PLUS	MT 3200C up PLUS	MT 3350up	MT 3350 C up	MT 3600up	MT 3600 C up	MT 3650up	MT 3650 C up	MT 3650up Touchscr	MT 3650 C up Touchscr	MT 3500 up	MT 3500 C up	MT 3800 up	MT 3800 C up	MT 3800 up Touchscr.	MT 3800 C up Touchscr	MT 3900C UP	MT 4000 C UP	
<b>CENTERING ADAPTORS</b>																							
 <p>CP4    PCF1    CF1</p>	8-21100080	<b>ARF Accessory for off-road wheels Ø 100 ÷118,5 mm, Ø 100 ÷129,5 mm</b>	<input type="checkbox"/>	<input type="checkbox"/>	<input type="checkbox"/>	<input type="checkbox"/>	<input type="checkbox"/>	<input type="checkbox"/>	<input type="checkbox"/>	<input type="checkbox"/>	<input type="checkbox"/>	<input type="checkbox"/>	<input type="checkbox"/>	<input type="checkbox"/>	<input type="checkbox"/>	<input type="checkbox"/>	<input type="checkbox"/>	<input type="checkbox"/>	<input type="checkbox"/>	<input type="checkbox"/>	<input type="checkbox"/>		
		CGF - Off-road wheel cone (vans) 4-103186	<input type="checkbox"/>	<input type="checkbox"/>	<input type="checkbox"/>	<input type="checkbox"/>	<input type="checkbox"/>	<input type="checkbox"/>	<input type="checkbox"/>	<input type="checkbox"/>	<input type="checkbox"/>	<input type="checkbox"/>	<input type="checkbox"/>	<input type="checkbox"/>	<input type="checkbox"/>	<input type="checkbox"/>	<input type="checkbox"/>	<input type="checkbox"/>	<input type="checkbox"/>	<input type="checkbox"/>	<input type="checkbox"/>	<input type="checkbox"/>	
		PCF1 - Wheel protector for centring alloy rims 4-115868	<input type="checkbox"/>	<input type="checkbox"/>	<input type="checkbox"/>	<input type="checkbox"/>	<input type="checkbox"/>	<input type="checkbox"/>	<input type="checkbox"/>	<input type="checkbox"/>	<input type="checkbox"/>	<input type="checkbox"/>	<input type="checkbox"/>	<input type="checkbox"/>	<input type="checkbox"/>	<input type="checkbox"/>	<input type="checkbox"/>	<input type="checkbox"/>	<input type="checkbox"/>	<input type="checkbox"/>	<input type="checkbox"/>	<input type="checkbox"/>	<input type="checkbox"/>
		CF1 - Wheel clamping cap 4-115863	<input type="checkbox"/>	<input type="checkbox"/>	<input type="checkbox"/>	<input type="checkbox"/>	<input type="checkbox"/>	<input type="checkbox"/>	<input type="checkbox"/>	<input type="checkbox"/>	<input type="checkbox"/>	<input type="checkbox"/>	<input type="checkbox"/>	<input type="checkbox"/>	<input type="checkbox"/>	<input type="checkbox"/>	<input type="checkbox"/>	<input type="checkbox"/>	<input type="checkbox"/>	<input type="checkbox"/>	<input type="checkbox"/>	<input type="checkbox"/>	<input type="checkbox"/>
	8-21100096	<b>Centering cone capacity</b> from Ø95 to Ø137 mm.	★	★	★	★	★	★	★	★	★	★	★	★	★	★	★	★	★	★	★	★	

# ACCESSORIES FOR CAR WHEEL BALANCERS



Image	Part-no	Description	MT 3100up	MT 3200up	MT 3200up PLUS	MT 3200C up PLUS	MT 3350up	MT 3350 C up	MT 3600up	MT 3600 C up	MT 3650up	MT 3650 C up	MT 3650up Touchscr	MT 3650 C up Touchscr	MT 3500 up	MT 3500 C up	MT 3800 up	MT 3800 C up	MT 3800 up Touchscr.	MT 3800 C up Touchscr	MT 3900C UP	MT 4000 C UP	
<b>CENTERING ADAPTORS</b>																							
 <ul style="list-style-type: none"> <li><b>B1</b> ø 56,6÷57,1 mm</li> <li><b>B2</b> ø 65÷67 mm</li> <li><b>B3</b> ø 73,2÷75,4 mm</li> <li><b>B4</b> ø 63,3÷64,2 mm</li> <li><b>B5</b> ø 58÷60,1 mm</li> <li><b>B7</b> ø 54÷56,1 mm</li> </ul>	8-21100082	<b>SBC</b> - Set of six centring bushes ø 40	★	★	★	★	★	★	★	★	★	★	★	★	★	★	★	★	★	★	★	★	
	4-105075	B1 - Smart (Mercedes), SEAT, Chevrolet, Fiat (Grande Punto), Opel, Audi, Skoda, VW																					
	4-105076	B2 - Citroen, Fiat (Scudo), Ford (Transit), Opel, Peugeot, Saab, Volvo, VW, Nissan, Audi (A4), Mercedes, Hyundai, Kia, Mazda, Mitsubishi																					
	4-105077	B3 - Aston Martin, BMW (X5, X6), Suzuki (Carry), Jaguar																					
	4-105078	B4 - Ford, Jaguar, Mazda (121, Mazda 2), Volvo, Honda, Alfa Romeo																					
	4-105079	B5 - Alfa Romeo, Citroen, Fiat, Lancia, Peugeot, Lada, Nissan, Dacia, Renault, Subaru, Toyota																					
	4-105080	B7 - Citroen (C1), Daihatsu, Hyundai, Kia, Mazda, Opel (Agila), Peugeot (106, 107), Subaru, Suzuki, Toyota, Honda, Mini (BMW), Proton																					



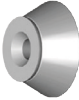

# ACCESSORIES FOR CAR WHEEL BALANCERS

Image	Part-no	Description	MT 3100up	MT 3200up	MT 3200up PLUS	MT 3200C up PLUS	MT 3350up	MT 3350 C up	MT 3600up	MT 3600 C up	MT 3650up	MT 3650 C up	MT 3650up Touchscr	MT 3650 C up Touchscr	MT 3500 up	MT 3500 C up	MT 3800 up	MT 3800 C up	MT 3800 up Touchscr.	MT 3800 C up Touchscr	MT 3900C UP	MT 4000 C UP
<b>CENTERING ADAPTORS</b>																						
	8-21100083	<b>B6</b> - "Racing" bush for Ferrari/Maserati Ø 67 mm	★	★	★	★	★	★	★	★	★	★	★	★	★	★	★	★	★	★	★	★
	8-21100085	<b>B9</b> - Bush OPEL Ø 56,5-65-70,1 mm	★	★	★	★	★	★	★	★	★	★	★	★	★	★	★	★	★	★	★	★
	8-21120004	<b>DX1-CF161</b> - Professional centring kits for Mercedes Benz Sprinter and Volkswagen Crafter commercial vehicles with 161mm ø central hole	★	★	★	★	★	★	★	★	★	★	★	★	★	★	★	★	★	★	★	★
	8-21100200	<b>CIP</b> - Intermediate cone Ø 55÷72 mm	★	★	★	★	★	★	★	★	★	★	★	★	★	★	★	★	★	★	★	★
	19131018	<b>Cone for off-the-road wheels</b> Ø 40 mm (88÷132 mm)	★	★	★	★	★	★	★	★	★	★	★	★	★	★	★	★	★	★	★	★

















# ACCESSORIES FOR CAR WHEEL BALANCERS

Image	Part-no	Description	MT 3100up	MT 3200up	MT 3200up PLUS	MT 3200C up PLUS	MT 3350up	MT 3350 C up	MT 3600up	MT 3600 C up	MT 3650up	MT 3650 C up	MT 3650up Touchscr	MT 3650 C up Touchscr	MT 3500 up	MT 3500 C up	MT 3800 up	MT 3800 C up	MT 3800 up Touchscr.	MT 3800 C up Touchscr	MT 3900C UP	MT 4000 C UP
<b>CENTERING ADAPTORS</b>																						
 <span>DX1</span> <span>CF1</span> <span>CF2</span>	8-21100141	<b>DX-CBF</b> - Pair of centering cone for van wheels (117-173 mm) with aluminium spacer Ø 40 mm	★	★	★	★	★	★	★	★	★	★	★	★	★	★	★	★	★	★	★	★
	4-107426	DX1 - Spacer																				
	4-107423	CF1 - Cone for vans ø 117÷147 mm																				
	4-107424	CF2 - Cone for van ø 143÷173 mm																				
 <span>ARS</span> <span>DARS</span>	8-21100089	<b>ARS</b> - "Racing" accessory for sports wheels, for use with Racing bush	★	★	★	★	★	★	★	★	★	★	★	★	★	★	★	★	★	★	★	★
	4-105171	<b>DARS</b> - Spacer 30 mm																				
 <span>B17</span> <span>B16</span>	8-21400022	<b>MERCEDES KIT</b> Ø 57, Ø 65, Ø 66,5, Ø 84 mm	★	★	★	★	★	★	★	★	★	★	★	★	★	★	★	★	★	★	★	★
	4-138168	B16    Ø 57, Ø 66,5, Ø 67 mm																				
	4-138169	B17    Ø 60, Ø 84 mm																				

# ACCESSORIES FOR CAR WHEEL BALANCERS

Image	Part-no	Description	MT 3100up	MT 3200up	MT 3200up PLUS	MT 3200C up PLUS	MT 3350up	MT 3350 C up	MT 3600up	MT 3600 C up	MT 3650up	MT 3650 C up	MT 3650up Touchscr	MT 3650 C up Touchscr	MT 3500 up	MT 3500 C up	MT 3800 up	MT 3800 C up	MT 3800 up Touchscr.	MT 3800 C up Touchscr	MT 3900C UP	MT 4000 C UP
<b>CENTERING ADAPTORS</b>																						
 <p>B11                      B6</p>	8-21100228	<b>BMW-MINI KIT</b> Ø 66.5, Ø 56.5, Ø 72.5, Ø 74 mm	★	★	★	★	★	★	★	★	★	★	★	★	★	★	★	★	★	★	★	★
	4-105103	B6            Ø 66.5 mm																				
	4-105108	B11            Ø 56.5 - Ø 72.5 - Ø 74 mm																				
	802459564	<b>Clamping hood</b> for alloy rims	★	★	★	★	★	★	★	★	★	★	★	★	★	★	★	★	★	★	★	★
	8-21100095	<b>PCD40-40</b> - Pneumatic quick nut for 40mm shaft	★	★	★		★		★		★		★		★		★		★			



# ACCESSORIES FOR CAR WHEEL BALANCERS

Image	Part-no	Description	MT 3100up	MT 3200up	MT 3200up PLUS	MT 3200C up PLUS	MT 3350up	MT 3350 C up	MT 3600up	MT 3600 C up	MT 3650up	MT 3650 C up	MT 3650up Touchscr	MT 3650 C up Touchscr	MT 3500 up	MT 3500 C up	MT 3800 up	MT 3800 C up	MT 3800 up Touchscr.	MT 3800 C up Touchscr	MT 3900C UP	MT 4000 C UP
<b>FLANGES</b>																						
 <p>per cerchi a 5 fori. Range bloccaggio 95,25 - 180 mm</p> <ul style="list-style-type: none"> <li> Ø 28</li> <li> Ø 22,5</li> <li> Ø 22,5</li> <li> Ø 19</li> </ul>	8-21100294	<p><b>PFM FASTPLATE 5</b> for 5-hole rims. Clamping range: 95,25 ÷ 180 mm</p> <p>3-05125 PLANETARY GEAR ASSEMBLY 3-05126 TORQUE TIP B Ø28 L:25MM 3-05127 TORQUE TIP C Ø22,5 L:40MM 3-05128 TORQUE TIP C Ø22,5 L:65MM 3-05129 TORQUE TIP E Ø19 L:40MM</p>	★	★	★	★	★	★	★	★	★	★	★	★	★	★	★	★	★	★	★	★
 <p>per cerchi a 3-4-6-8 fori. Range bloccaggio 95,25 - 180 mm</p> <ul style="list-style-type: none"> <li> Ø 28</li> <li> Ø 22,5</li> <li> Ø 22,5</li> <li> Ø 19</li> </ul>	8-21100295	<p><b>PFM FASTPLATE 3-4-6-8</b> for 3-4-6-8-hole rims. Clamping range: 95,25÷180 mm</p> <p>3-05125 PLANETARY GEAR ASSEMBLY 3-05126 TORQUE TIP B Ø28 L:25MM 3-05127 TORQUE TIP C Ø22,5 L:40MM 3-05128 TORQUE TIP C Ø22,5 L:65MM 3-05129 TORQUE TIP E Ø19 L:40MM</p>	★	★	★	★	★	★	★	★	★	★	★	★	★	★	★	★	★	★	★	★
 <p>8-21100296 <b>PFM FASTPLATE KIT</b> per cerchi a 3-4-5-6-8 fori. Range bloccaggio 95,25 - 180 mm</p> <ul style="list-style-type: none"> <li> Ø 28</li> <li> Ø 22,5</li> <li> Ø 22,5</li> <li> Ø 19</li> </ul>	8-21100296	<p><b>PFM FASTPLATE KIT</b> for 3-4-5-6-8-hole rims. (it includes P/N 8-21100294 and P/N 8-21100295) Clamping range: 95,25÷180 mm</p> <p>3-05125 PLANETARY GEAR ASSEMBLY 3-05126 TORQUE TIP B Ø28 L:25MM 3-05127 TORQUE TIP C Ø22,5 L:40MM 3-05128 TORQUE TIP C Ø22,5 L:65MM 3-05129 TORQUE TIP E Ø19 L:40MM</p>	★	★	★	★	★	★	★	★	★	★	★	★	★	★	★	★	★	★	★	★
	8-21100297	<p><b>PFM-C SLEEVE HANDLE</b> Sleeve for wheel balancers with automatic clamping. To be screwed directly to the FASTPLATE to work more comfortably and quickly</p>	-	-	-	★	-	★	-	★	-	★	-	★	-	★	-	★	-	★	★	★

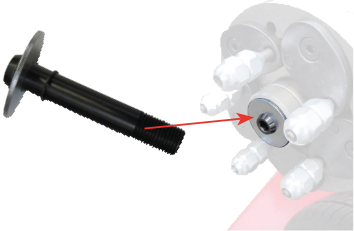

# ACCESSORIES FOR CAR WHEEL BALANCERS

Image	Part-no	Description	MT 3100up	MT 3200up	MT 3200up PLUS	MT 3200C up PLUS	MT 3350up	MT 3350 C up	MT 3600up	MT 3600 C up	MT 3650up	MT 3650 C up	MT 3650up Touchscr	MT 3650 C up Touchscr	MT 3500 up	MT 3500 C up	MT 3800 up	MT 3800 C up	MT 3800 up Touchscr.	MT 3800 C up Touchscr	MT 3900C UP	MT 4000 C UP
<b>FLANGES</b>																						
	8-21100152	<b>FPF BASIC</b> - Universal flange kit for wheels with central hole	★	★	★	★	★	★	★	★	★	★	★	★	★	★	★	★	★	★	★	★
	4-109127	HLT2 - Short cap, ø 22,5 L 58																				
	4-108097	PET - Basic Petal																				
	8-21100145	<b>FPF-2 BMW</b> - BMW flange kit for wheels with central hole - ø 4 x 100 / 5 x 120 / 5 x 112 -	★	★	★	★	★	★	★	★	★	★	★	★	★	★	★	★	★	★	★	★
	8-21100091	<b>FRU-SA D.40</b> - Universal flange for wheels with or without central hole.	★	★	★	★	★	★	★	★	★	★	★	★	★	★	★	★	★	★	★	★
	2401415	FT1 Connecting rod with pin																				
	321878	DEB Conical/spheric nut for wheel fixing																				
	4-105877	CHT6 T Hexagonal key CH 6																				
	441286	RFS Caliper																				
	426517	CEP Hexagonal key CH 22																				
600906	CHI 6 Hexagonal key CH 6																					



# ACCESSORIES FOR CAR WHEEL BALANCERS

Image	Part-no	Description	MT 3100up	MT 3200up	MT 3200up PLUS	MT 3200C up PLUS	MT 3350up	MT 3350 C up	MT 3600up	MT 3600 C up	MT 3650up	MT 3650 C up	MT 3650up Touchscr	MT 3650 C up Touchscr	MT 3500 up	MT 3500 C up	MT 3800 up	MT 3800 C up	MT 3800 up Touchscr.	MT 3800 C up Touchscr	MT 3900C UP	MT 4000 C UP
<b>FLANGES</b>																						
	8-21100207	<b>Locking disc</b> for BVFF bushes for FRU flange, for wheel balancers with manual clamping	★	★	★		★		★		★		★		★		★		★			
	8-21100208	<b>Locking disc</b> for BVFF bushes for FRU flange, for wheel balancers with automatic "C" clamping				★		★		★		★		★		★		★		★	★	★
 <ul style="list-style-type: none"> <li>BF1</li> <li>BF2</li> <li>BF3</li> <li>BF4</li> <li>BF5</li> </ul>	8-21100092	<b>BVFF</b> - Set of five bushes for precise centring on FRU flange	★	★	★	★	★	★	★	★	★	★	★	★	★	★	★	★	★	★	★	★
	4-105110	BF1 - Bushing ø 55 Peugeot																				
	4-105174	BF2 - Bushing ø 58,1 Fiat Ritmo e Citroën CX/Evasion, Peugeot 806																				
	4-105175	BF3 - Bushing ø 60,1 Renault																				
	4-105176	BF4 - Bushing ø 65 Peugeot, Citroën																				
	4-106570	BF5 - Bushing ø 57 BMW,VW, AUDI, SEAT																				

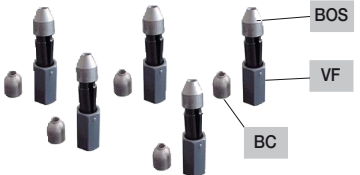
# ACCESSORIES FOR CAR WHEEL BALANCERS

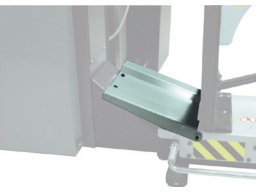

Image	Part-no	Description	MT 3100up	MT 3200up	MT 3200up PLUS	MT 3200C up PLUS	MT 3350up	MT 3350 C up	MT 3600up	MT 3600 C up	MT 3650up	MT 3650 C up	MT 3650up Touchscr	MT 3650 C up Touchscr	MT 3500 up	MT 3500 C up	MT 3800 up	MT 3800 C up	MT 3800 up Touchscr.	MT 3800 C up Touchscr	MT 3900C UP	MT 4000 C UP
<b>FLANGES</b>																						
	802322075	<b>DCL</b> - Set of five conical nuts for alloy rims with FRU flange	★	★	★	★	★	★	★	★	★	★	★	★	★	★	★	★	★	★	★	★
	802322076	<b>DMS</b> - Set of five spherical nuts for alloy rims with FRU flange	★	★	★	★	★	★	★	★	★	★	★	★	★	★	★	★	★	★	★	★
	802231479	<b>SDR</b> - Set of five special nuts for quick wheel fastening	★	★	★	★	★	★	★	★	★	★	★	★	★	★	★	★	★	★	★	★
	431481	BC - Conical bush																				
	431482	BOS - Spheric bush																				
	431480	VF - Quick fixing screw																				

# ACCESSORIES FOR CAR WHEEL BALANCERS







Image	Part-no	Description	MT 3100up	MT 3200up	MT 3200up PLUS	MT 3200C up PLUS	MT 3350up	MT 3350 C up	MT 3600up	MT 3600 C up	MT 3650up	MT 3650 C up	MT 3650up Touchscr	MT 3650 C up Touchscr	MT 3500 up	MT 3500 C up	MT 3800 up	MT 3800 C up	MT 3800 up Touchscr.	MT 3800 C up Touchscr	MT 3900C UP	MT 4000 C UP
<b>LIFTERS</b>																						
	8-21100230	<b>WL-0</b> Pneumatic wheel lifter. Lifting capacity 80 kg. - Weightless effect -  AUTOMATIC	★	★	★	★	★	★	★	★	★	★	★	★	★	★	★	★	★	★	★	★
	8-21100248	<b>WL-R</b> Professional adjustable scissor for wheel lifter. One handed control.  MANUAL	★	★	★	★	★	★	★	★	★	★	★	★	★	★	★	★	★	★	★	★
IMAGE NOT AVAILABLE	8-21100231	<b>Mounting kit</b> for WL-0 and WL-R	★	★	★	★	★	★	★	★	★	★	★	★								
	8-21600132	<b>Flap kit</b> for WL-0 and WL-R (it allows to mount the lifter on wheel balancers with lateral foot)	★	★	★	★			★	★												



# ACCESSORIES FOR CAR WHEEL BALANCERS

Image	Part-no	Description	MT 3100up	MT 3200up	MT 3200up PLUS	MT 3200C up PLUS	MT 3350up	MT 3350 C up	MT 3600up	MT 3600 C up	MT 3650up	MT 3650 C up	MT 3650up Touchscr	MT 3650 C up Touchscr	MT 3500 up	MT 3500 C up	MT 3800 up	MT 3800 C up	MT 3800 up Touchscr.	MT 3800 C up Touchscr	MT 3900C UP	MT 4000 C UP
<b>LIFTERS</b>																						
	8-21100161	<b>WL 80</b> - Pneumatic wheel lifter. Lifting capacity 80 kg.	★	★	★	★	★	★	★	★	★	★	★	★	★	★	★	★	★	★	★	★
	8-21100163	<b>FTT1</b> Mounting sets for WL 80	★	★	★	★	★	★	★	★	★	★	★	★								
	8-21120002	<b>FTT2</b> Mounting sets for WL 80													★	★	★	★	★	★	★	★

# ACCESSORIES FOR CAR WHEEL BALANCERS

Image	Part-no	Description	MT 3100up	MT 3200up	MT 3200up PLUS	MT 3200C up PLUS	MT 3350up	MT 3350 C up	MT 3600up	MT 3600 C up	MT 3650up	MT 3650 C up	MT 3650up Touchscr	MT 3650 C up Touchscr	MT 3500 up	MT 3500 C up	MT 3800 up	MT 3800 C up	MT 3800 up Touchscr.	MT 3800 C up Touchscr	MT 3900C UP	MT 4000 C UP
<b>calibration and technical support systems</b>																						
	8-21100221	<b>SLUG</b> - Calibration tool to retrofit old balancers	★	★	★	★	★	★	★	★	★	★	★	★	★	★	★	★	★	★	★	★
	8-21100224	<b>Serial cable RS232</b> AMP MODU II to update the firmware of PC board (MBU - MBE - SEB)" - Accessory for Service Centers -	★	★	★	★	★	★	★	★	★	★	★	★	★	★	★	★	★	★	★	★
	8-21100225	Bead <b>depressor clamp</b>	★	★	★	★	★	★	★	★	★	★	★	★	★	★	★	★	★	★	★	★
	8-21100226	<b>Adapter USB-RS232</b> - To connect USB port onboard of pc and laptop of last generation to RS232 port. - Accessory for Service Centers -	★	★	★	★	★	★	★	★	★	★	★	★	★	★	★	★	★	★	★	★
	8-21120001	<b>Laser calibrator</b> - Accessory for Service Centers -																			★	★
	802461006	Adhesive <b>weight remover</b>	★	★	★	★	★	★	★	★	★	★	★	★	★	★	★	★	★	★	★	★

# ACCESSORIES FOR WHEEL BALANCERS FOR MOTORBIKE

## CENTERING AND CLAMPING ACCESSORIES FOR MOTORCYCLE WHEELS

In the range of accessories for off-the-vehicle wheel balancers is now available the new BIKES UNIVERSAL KIT with various additional sets for centering and dynamic balancing of motorcycle wheels.  
Easy to install and quickly to use. Ideal for small scooter wheels up to 21 inches large off-road type; without forgetting the wide chopper type and those monolever without bearings.  
Balancing results excellent!  
Universal for all wheel balancers in range both manual and automatic clamping.

### EXAMPLE OF USE



Shaft with centering cones.

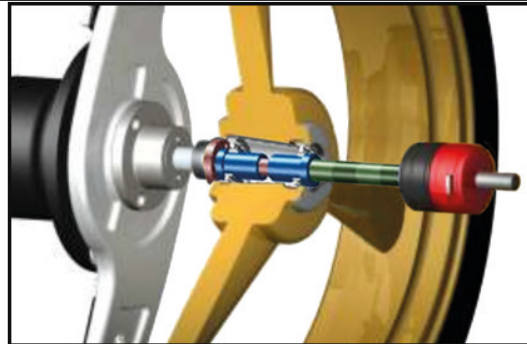

Shaft with centering sleeves.

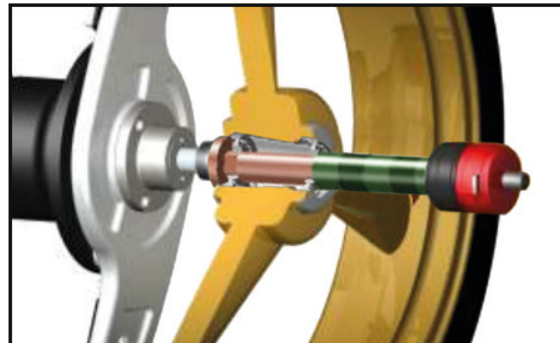

Motorcycle shaft with same diameter as the floating bearing.

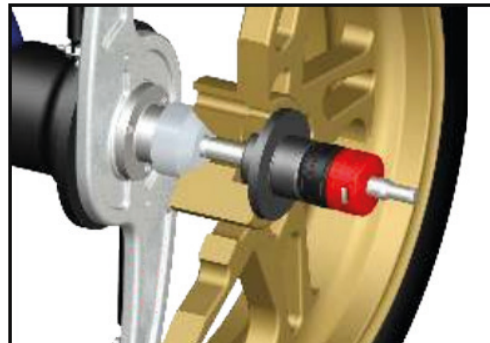

Shaft with special centering kit.

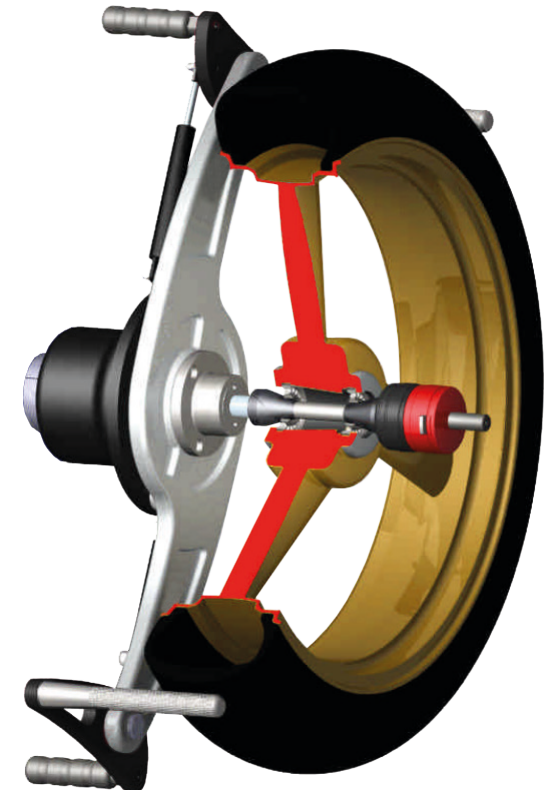



# ACCESSORIES FOR MOTORBIKES WHEEL BALANCERS

Image	Part-no	Description	MT 3100up	MT 3200up	MT 3200up PLUS	MT 3200C up PLUS	MT 3350up	MT 3350 C up	MT 3600up	MT 3600 C up	MT 3650up	MT 3650 C up	MT 3650up Touchscr	MT 3650 C up Touchscr	MT 3500 up	MT 3500 C up	MT 3800 up	MT 3800 C up	MT 3800 up Touchscr.	MT 3800 C up Touchscr	MT 3900C UP	MT 4000 C UP
-------	---------	-------------	-----------	-----------	----------------	------------------	-----------	--------------	-----------	--------------	-----------	--------------	--------------------	-----------------------	------------	--------------	------------	--------------	----------------------	-----------------------	-------------	--------------

## ACCESSORIES FOR MOTORCYCLE

	<p>8-21120012</p>	<p><b>BIKE UNIVERSAL KIT</b> Basic device for balancing motorcycles and scooters wheels. Wheel holder shaft 14 mm. * Motorcycle extension gauge NOT included</p> <table border="1"> <tr><td>1</td><td>DRAGGING GROUP</td><td>3-03408</td></tr> <tr><td>2</td><td>CYLINDRICAL CHUCK</td><td>3-03409</td></tr> <tr><td>3</td><td>Hexagon socket screw M 6x14</td><td>3-03410</td></tr> <tr><td>4</td><td>Single head wrench SW50</td><td>3-03411</td></tr> <tr><td>5</td><td>Wheel holder shaft Ø 14 mm</td><td>3-03412</td></tr> <tr><td>6</td><td>Centering cone 15÷30 mm</td><td>3-03413</td></tr> <tr><td>7</td><td>Centering cone 16÷45 mm (Scooter)</td><td>3-03414</td></tr> <tr><td>8</td><td>Quick Fix for shaft Ø 14 mm</td><td>3-03415</td></tr> <tr><td>9</td><td>Wall board</td><td>3-03416</td></tr> <tr><td>10</td><td>Short spacer</td><td>3-03417</td></tr> <tr><td>11</td><td>M 14 Knurled nut</td><td>3-03418</td></tr> <tr><td>12</td><td>Hexagon socket head key SW4</td><td>3-03419</td></tr> <tr><td>13</td><td>Centering sleeve Ø 15 mm</td><td>3-03420</td></tr> <tr><td>14</td><td>Centering sleeve Ø 17 mm</td><td>3-03421</td></tr> <tr><td>15</td><td>Centering sleeve Ø 20 mm</td><td>3-03422</td></tr> <tr><td>16</td><td>PIAGGIO Centering sleeve</td><td>3-03423</td></tr> <tr><td>17</td><td>BMW/HONDA Pressure piece</td><td>3-03407</td></tr> </table>	1	DRAGGING GROUP	3-03408	2	CYLINDRICAL CHUCK	3-03409	3	Hexagon socket screw M 6x14	3-03410	4	Single head wrench SW50	3-03411	5	Wheel holder shaft Ø 14 mm	3-03412	6	Centering cone 15÷30 mm	3-03413	7	Centering cone 16÷45 mm (Scooter)	3-03414	8	Quick Fix for shaft Ø 14 mm	3-03415	9	Wall board	3-03416	10	Short spacer	3-03417	11	M 14 Knurled nut	3-03418	12	Hexagon socket head key SW4	3-03419	13	Centering sleeve Ø 15 mm	3-03420	14	Centering sleeve Ø 17 mm	3-03421	15	Centering sleeve Ø 20 mm	3-03422	16	PIAGGIO Centering sleeve	3-03423	17	BMW/HONDA Pressure piece	3-03407		★	★	★	★	★	★	★	★	★	★	★	★	★	★	★	★	★	★	★	★	★	★	★
1	DRAGGING GROUP	3-03408																																																																											
2	CYLINDRICAL CHUCK	3-03409																																																																											
3	Hexagon socket screw M 6x14	3-03410																																																																											
4	Single head wrench SW50	3-03411																																																																											
5	Wheel holder shaft Ø 14 mm	3-03412																																																																											
6	Centering cone 15÷30 mm	3-03413																																																																											
7	Centering cone 16÷45 mm (Scooter)	3-03414																																																																											
8	Quick Fix for shaft Ø 14 mm	3-03415																																																																											
9	Wall board	3-03416																																																																											
10	Short spacer	3-03417																																																																											
11	M 14 Knurled nut	3-03418																																																																											
12	Hexagon socket head key SW4	3-03419																																																																											
13	Centering sleeve Ø 15 mm	3-03420																																																																											
14	Centering sleeve Ø 17 mm	3-03421																																																																											
15	Centering sleeve Ø 20 mm	3-03422																																																																											
16	PIAGGIO Centering sleeve	3-03423																																																																											
17	BMW/HONDA Pressure piece	3-03407																																																																											
	<p>8-21100257</p>	<p>Ø10mm <b>Centering shaft</b> extra-long 230mm, for possible completion of code 8-21120012</p> <table border="1"> <tr><td>1</td><td>SHAFT Ø 10 MM</td><td>3-03864</td></tr> <tr><td>2</td><td>SPACER</td><td>3-03865</td></tr> <tr><td>3</td><td>CENTERING CONE D. 12÷20 MM</td><td>3-03866</td></tr> <tr><td>4</td><td>RING NUT M 10</td><td>3-03867</td></tr> </table>	1	SHAFT Ø 10 MM	3-03864	2	SPACER	3-03865	3	CENTERING CONE D. 12÷20 MM	3-03866	4	RING NUT M 10	3-03867		★	★	★	★	★	★	★	★	★	★	★	★	★	★	★	★	★	★	★	★	★	★	★																																							
1	SHAFT Ø 10 MM	3-03864																																																																											
2	SPACER	3-03865																																																																											
3	CENTERING CONE D. 12÷20 MM	3-03866																																																																											
4	RING NUT M 10	3-03867																																																																											

# ACCESSORIES FOR MOTORBIKES WHEEL BALANCERS

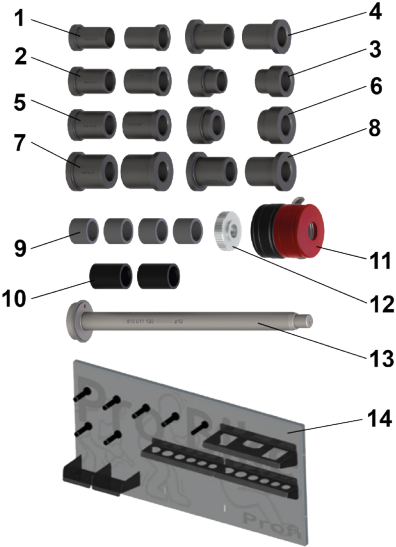
Image	Part-no	Description	MT 3100up	MT 3200up	MT 3200up PLUS	MT 3200C up PLUS	MT 3350up	MT 3350 C up	MT 3600up	MT 3600 C up	MT 3650up	MT 3650 C up	MT 3650up Touchscr	MT 3650 C up Touchscr	MT 3500 up	MT 3500 C up	MT 3800 up	MT 3800 C up	MT 3800 up Touchscr.	MT 3800 C up Touchscr	MT 3900C UP	MT 4000 C UP																																										
	8-21100116	Motorcycle <b>wheel distance gauge extensions</b> with clip P/N 8-21100159													★	★	★	★	★	★	★	★																																										
	8-21100155	Motorcycle <b>wheel distance gauge extensions</b> without clip	★	★	★	★	★	★	★	★	★	★	★	★																																																		
 <p>1 2 5 7 9 10 11 12 13 14</p>	8-21120013	<b>BIKE UPGRADE KIT 19</b> Additional module to BIKE UNIVERSAL KIT. <table border="1" data-bbox="703 801 1189 1225"> <tr><td>1</td><td>CENTERING SLEEVE D. 22 mm</td><td>3-03383</td></tr> <tr><td>2</td><td>CENTERING SLEEVE D. 25,4 mm</td><td>3-03384</td></tr> <tr><td>3</td><td>CENTERING SLEEVE D. 25 mm</td><td>3-03385</td></tr> <tr><td>4</td><td>CENTERING SLEEVE D. 26 mm</td><td>3-03386</td></tr> <tr><td>5</td><td>CENTERING SLEEVE D. 28 mm</td><td>3-03387</td></tr> <tr><td>6</td><td>CENTERING SLEEVE D. 32 mm</td><td>3-03388</td></tr> <tr><td>7</td><td>CENTERING SLEEVE D. 35 mm</td><td>3-03389</td></tr> <tr><td>8</td><td>CENTERING SLEEVE D. 30 mm</td><td>3-03390</td></tr> <tr><td>9</td><td>Short spacer D. 20 mm</td><td>3-03391</td></tr> <tr><td>10</td><td>HARLEY D. PRESSURE SWITCH</td><td>3-03392</td></tr> <tr><td>11</td><td>Quick Fix for shaft D. 19</td><td>3-03393</td></tr> <tr><td>12</td><td>M 14 Knurled nut</td><td>3-03418</td></tr> <tr><td>13</td><td>Wheel holder shaft D. 19 mm</td><td>3-03396</td></tr> <tr><td>14</td><td>Wall board</td><td>3-03395</td></tr> </table>	1	CENTERING SLEEVE D. 22 mm	3-03383	2	CENTERING SLEEVE D. 25,4 mm	3-03384	3	CENTERING SLEEVE D. 25 mm	3-03385	4	CENTERING SLEEVE D. 26 mm	3-03386	5	CENTERING SLEEVE D. 28 mm	3-03387	6	CENTERING SLEEVE D. 32 mm	3-03388	7	CENTERING SLEEVE D. 35 mm	3-03389	8	CENTERING SLEEVE D. 30 mm	3-03390	9	Short spacer D. 20 mm	3-03391	10	HARLEY D. PRESSURE SWITCH	3-03392	11	Quick Fix for shaft D. 19	3-03393	12	M 14 Knurled nut	3-03418	13	Wheel holder shaft D. 19 mm	3-03396	14	Wall board	3-03395																				
1	CENTERING SLEEVE D. 22 mm	3-03383																																																														
2	CENTERING SLEEVE D. 25,4 mm	3-03384																																																														
3	CENTERING SLEEVE D. 25 mm	3-03385																																																														
4	CENTERING SLEEVE D. 26 mm	3-03386																																																														
5	CENTERING SLEEVE D. 28 mm	3-03387																																																														
6	CENTERING SLEEVE D. 32 mm	3-03388																																																														
7	CENTERING SLEEVE D. 35 mm	3-03389																																																														
8	CENTERING SLEEVE D. 30 mm	3-03390																																																														
9	Short spacer D. 20 mm	3-03391																																																														
10	HARLEY D. PRESSURE SWITCH	3-03392																																																														
11	Quick Fix for shaft D. 19	3-03393																																																														
12	M 14 Knurled nut	3-03418																																																														
13	Wheel holder shaft D. 19 mm	3-03396																																																														
14	Wall board	3-03395																																																														
			★	★	★	★	★	★	★	★	★	★	★	★	★	★	★	★	★	★	★	★																																										

# ACCESSORIES FOR MOTORBIKES

## WHEEL BALANCERS

Image	Part-no	Description	MT 3100up	MT 3200up	MT 3200up PLUS	MT 3200C up PLUS	MT 3350up	MT 3350 C up	MT 3600up	MT 3600 C up	MT 3650up	MT 3650 C up	MT 3650up Touchscr	MT 3650 C up Touchscr	MT 3500 up	MT 3500 C up	MT 3800 up	MT 3800 C up	MT 3800 up Touchscr.	MT 3800 C up Touchscr	MT 3900C UP	MT 4000 C UP	
<b>ACCESSORIES FOR MOTORCYCLE</b>																							
	8-21120014	<b>BIKE MONOLEVER KIT 19</b> Additional module to BIKE UPGRADE KIT for motorcycle wheels with monolever.																					
		1	Centering sleeve ducati/triumph	3-03397																			
		2	Centering sleeve MV AGUSTA/HONDA	3-03398																			
		3	Centering sleeve HONDA GL 1800 / NTV 650	3-03399																			
		4	Centering sleeve APRILIA/BMW/YAMAHA	3-03400																			
		5	Centering sleeve TRIUMPH/HONDA VFR1200	3-03401	★	★	★	★	★	★	★	★	★	★	★	★	★	★	★	★	★	★	★
		6	PRESSUR PIECE	3-03402																			
		7	Centering FLANGE KTM SUPERDUKE+ TRIUMPH	3-03403																			
		8	SPACING SLEEVE, LONG	3-03404																			
		9	Centering disc BMW II (from year of manufacture 2005) also r v1200 gs	3-03405																			
10	Centering disc BMW I (from year of manufacture 2005) apart r v1200 gs, moto guzzi (FROM 2008) (INTERNAL Ø 14)	3-03406																					
	8-21120016	Ø14mm <b>Centering shaft extra-long</b> 318mm, as possible completion of code 8-21120012	★	★	★	★	★	★	★	★	★	★	★	★	★	★	★	★	★	★	★		
	8-21120017	Ø19mm <b>Centering shaft extra-long</b> 365mm, as possible completion of code 8-21120013	★	★	★	★	★	★	★	★	★	★	★	★	★	★	★	★	★	★	★		

# WHEEL BALANCERS FOR "CAR MOBILE SERVICE"

## MT3000 UP - TILT UP HAND SPIN

### STANDARD ACCESSORIES

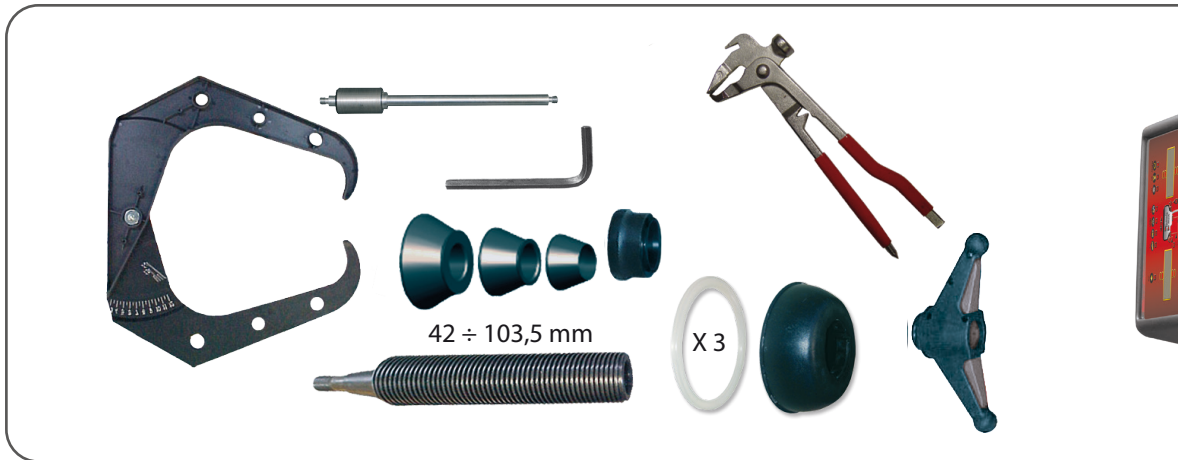

Part-no	Electrical Supply	Description
0-21330000/16	100-230V/1Ph/50-60Hz	<b>MT3000 UP - TILT UP Hand Spin</b> Special version for mobile service, compact in dimensions and weight. Ideal to work inside the van thanks to the possibility of tilting the measuring unit to vertical position. Manual spin version, AutoSelect automatic wheel size detection. Lever operated brake.

# WHEEL BALANCERS FOR "CAR MOBILE SERVICE"

## MT3000 UP VAN MOTORIZED SPIN

### STANDARD ACCESSORIES

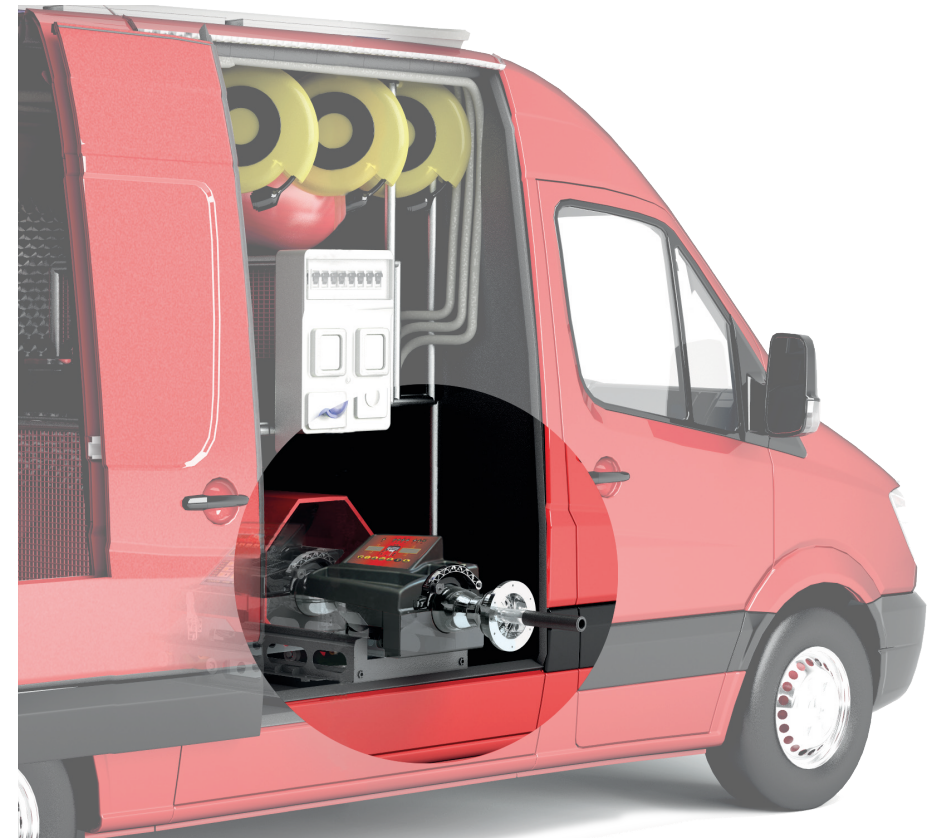
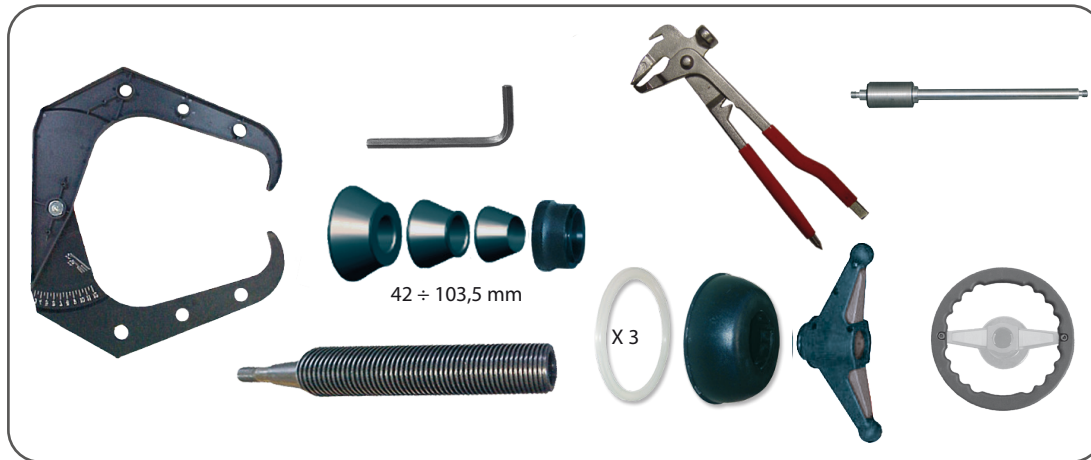

Part-no	Electrical Supply	Description	
0-21330001/16	200-230V/1Ph/50-60Hz	<b>MT3000 UP VAN Motorized Spin</b> Special version for mobile service, compact in dimensions and weight. It can be extracted from the side door and allows working comfortably outside the van. Lever-actuated motorized spin version, AutoSelect automatic wheel size detection. Lever operated brake.	



# WHEEL BALANCERS FOR "CAR MOBILE SERVICE"



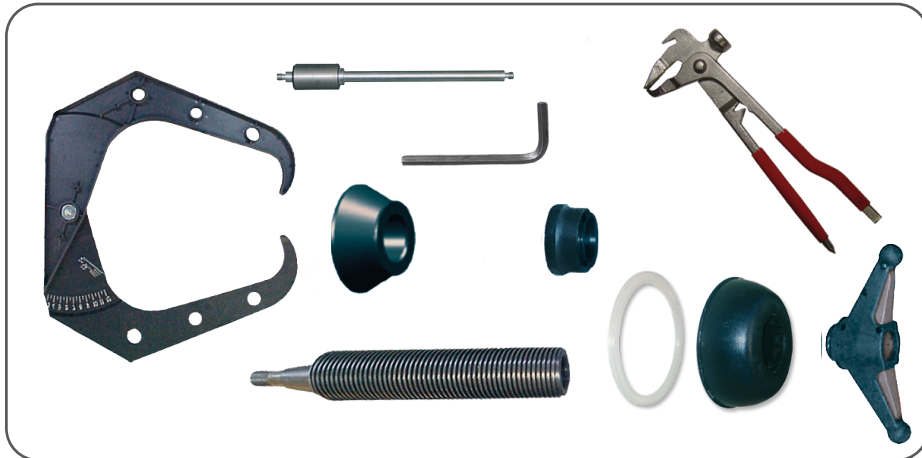

## MT3000 UP WORKBENCH HAND SPIN

### STANDARD ACCESSORIES





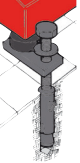

Part-no	Electrical Supply	Description
0-21330002/16	200-230V/1Ph/50-60Hz	<b>MT3000 Up WORKBENCH - Hand Spin.</b> Extremely compact wheel balancer. it can be fixed to a workbench. For hobbyists, small workshops or for mobile service. AutoSelect 28" automatic wheel size detection. Lever operated brake. Manual spin version.

## ACCESSORIES WHEEL BALANCERS FOR "CAR MOBILE SERVICE"

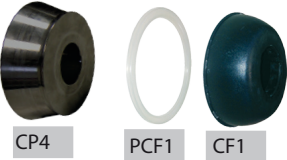
Image	Part-no	Description		MT 3000 TILT UP	MT 3000 VAN	MT 3000 WB
	8-21101100/XX	<b>PL</b> -side foot for installation without anchoring to floor; available in red (/16) and grey (/90) color		★		
	8-21101200	<b>Trolley Kit</b> for an easier handling (not for MT3000 UP VAN version)		★		
	8-21101000	<b>AL12</b> - 12v power supply kit		★		★
	8-21101010	<b>KFTU Kit</b> - anchoring kit to floor		★		
	8-21120022	<b>LASER PLANE KIT:</b> Upgrade kit to guide the operator in choosing the rim's inner planes without any errors and with extremely good visibility		★	★	★

# ACCESSORIES WHEEL BALANCERS FOR "CAR MOBILE SERVICE"

Image	Part-no	Description	MT 3000 TILT UP	MT 3000 VAN	MT 3000 WB
 <p>CP4    PCF1    CF1</p>	8-21100080	<b>ARF</b> Accessory for off-road wheels Ø 100 ÷ 118,5 mm, Ø 100 ÷ 129,5 mm	★	★	★
		CGF - Off-road wheel cone (vans) 4-103186			
		PCF1 - Wheel protector for centring alloy rims 4-115868			
		CF1 - Wheel clamping cap 4-115863			
	8-21100096	<b>Centering cone capacity</b> from Ø95 to Ø137 mm.	★	★	★
 <p>DX1    CF1    CF2</p>	8-21100141	<b>DX-CBF</b> - Kit centraggio furgoni e fuoristrada Ø117÷173mm	★	★	★
	4-107426	X1 - Spacer			
	4-107423	CF1 - Cone for vans ø 117÷147 mm			
	4-107424	CF2 - Cone for van ø 143÷173 mm			
 <p>B1 ø 56,6÷57,1 mm B2 ø 65÷67 mm B3 ø 73,2÷75,4 mm B4 ø 63,3÷64,2 mm B5 ø 58÷60,1 mm B7 ø 54÷56,1 mm</p>	8-21100082	<b>SBC</b> - Serie di 6 boccole centraggio Ø 40 mm	★	★	★
	4-105075	B1 - Smart (Mercedes), SEAT, Chevrolet, Fiat (Grande Punto), Opel, Audi, Skoda, VW			
	4-105076	B2 - Citroen, Fiat (Scudo), Ford (Transit), Opel, Peugeot, Saab, Volvo, VW, Nissan, Audi (A4), Mercedes, Hyundai, Kia, Mazda, Mitsubishi			
	4-105077	B3 - Aston Martin, BMW (X5, X6), Suzuki (Carry), Jaguar			
	4-105078	B4 - Ford, Jaguar, Mazda (121, Mazda 2), Volvo, Honda, Alfa Romeo			
	4-105079	B5 - Alfa Romeo, Citroen, Fiat, Lancia, Peugeot, Lada, Nissan, Dacia, Renault, Subaru, Toyota			
	4-105080	B7 - Citroen (C1), Daihatsu, Hyundai, Kia, Mazda, Opel (Agila), Peugeot (106, 107), Subaru, Suzuki, Toyota, Honda, Mini (BMW), Proton			

# WHEEL BALANCERS FOR "TRUCK MOBILE SERVICE"



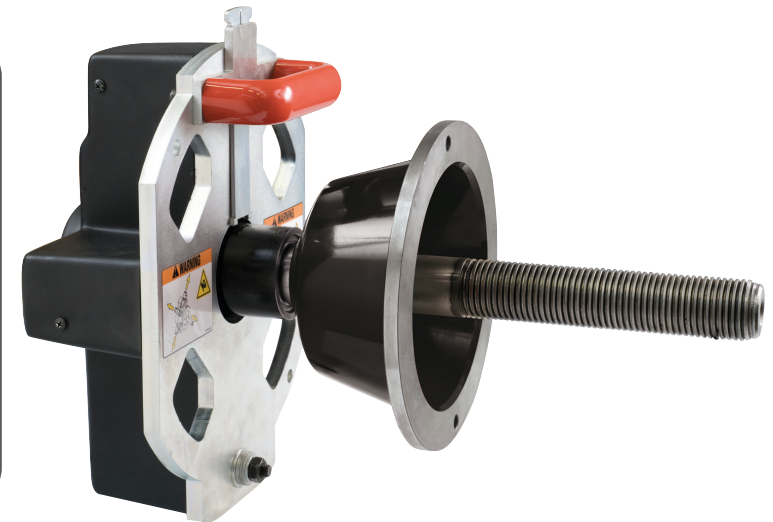

## MT6310 MOBILE TRUCK

### STANDARD ACCESSORIES

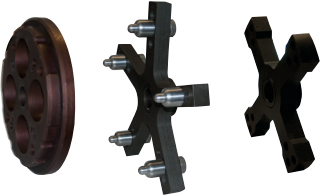

Part-no	Electrical Supply	Description	
0-21101050/34	100-230V/1Ph/50-60Hz	<b>MT6310 MOBILE TRUCK</b> - Portable wheel balancer for truck and bus tyres, compact in dimensions and weight; It can be fit on every type of chuck tyre changer for truck. Specially designed for the mobile service and for workshops having a reduced working space.	
8-21306311		<b>Compulsory customizing</b> MT6310 Mobile Truck	

## ACCESSORIES WHEEL BALANCERS FOR "TRUCK MOBILE SERVICE"

Image	Part-no	Description		MT 6310
	8-21900220	<b>ART40</b> - TRUCKS FLANGES CENTERING KIT		★
	8-21100278	<b>CAR MATE KIT</b> centering and clamping kit $\varnothing 42\div 103,5$ mm		★
	8-11100261	<b>GGR40 Centering kit</b> $\varnothing 40$ for central hole wheels 183,5÷223 mm - 17,5"-19.5"rims (IVECO-MAN- DAF)		★
	8-21101052	<b>Trolley kit</b> for storage stand		★

# TRUCK WHEEL BALANCERS

## MT2450 EASY-ALU

### STANDARD ACCESSORIES

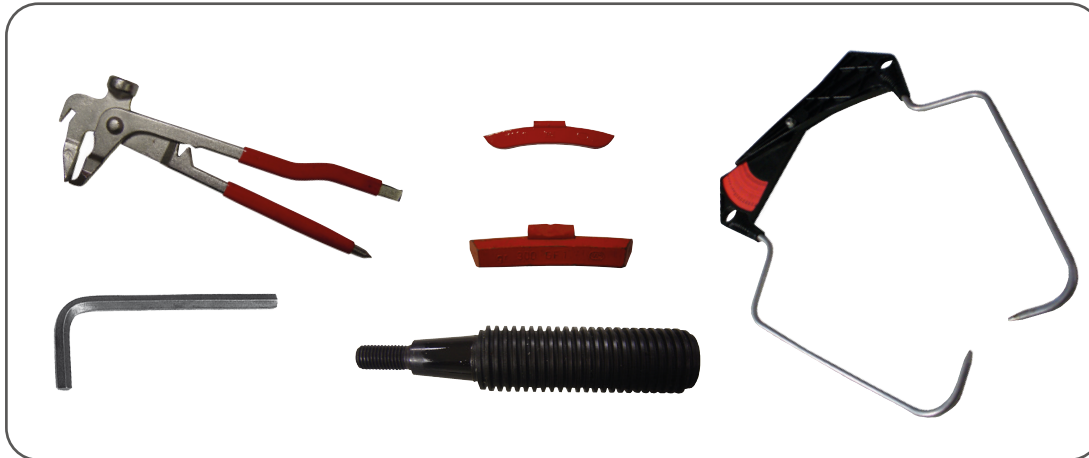

Part-no	Electrical Supply	Description	
0-21108401/16	200-230V/1Ph/50-60Hz	<b>MT2450 EASY-ALU</b> - LED display, motorized machine for truck wheels with automatic data input, including wheel lifter and wheel guard.	
0-21108402/16	100-115V/1Ph/50-60Hz	As above, with <b>different power supply</b>	

# TRUCK WHEEL BALANCERS

## MT2650 EASY-ALU

### STANDARD ACCESSORIES

Monitor not included

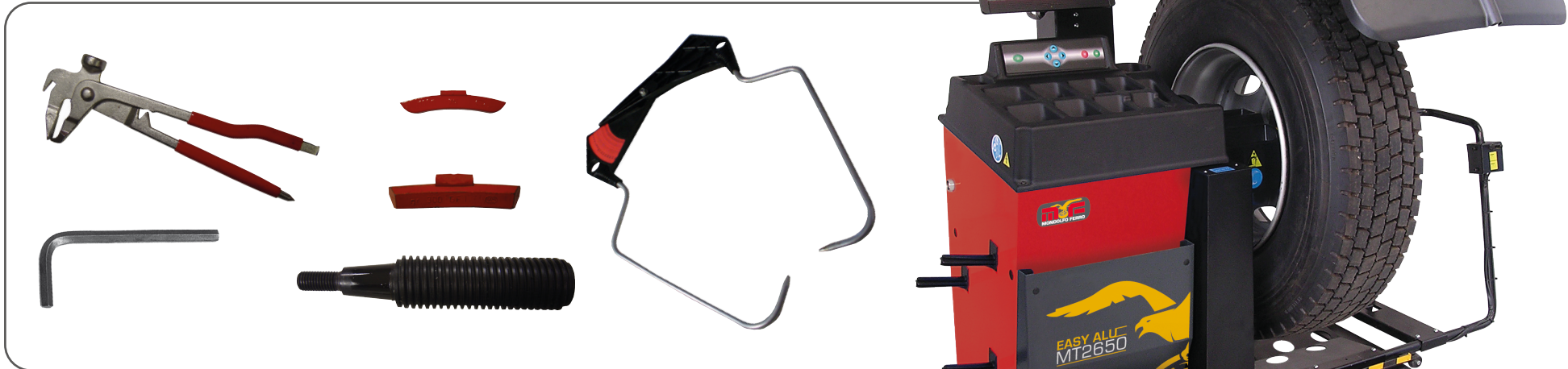

Part-no	Electrical Supply	Description	
0-21108301/16	200-230V/1Ph/50-60Hz	<b>MT2650 EASY-ALU</b> - Motorized machine for truck wheels with automatic data input, including wheel lifter and wheel guard.	

# TRUCK WHEEL BALANCERS

## MT6350

### STANDARD ACCESSORIES



cod.  
802227308



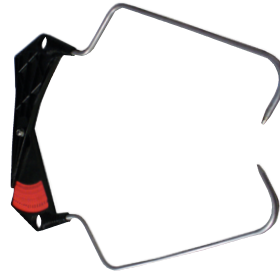

cod.  
238304





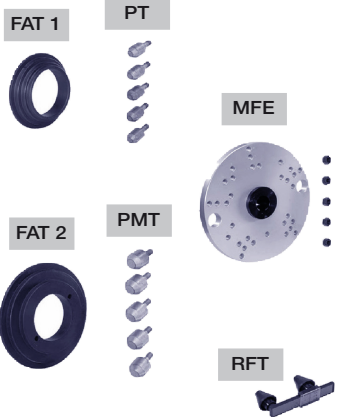

Part-no	Electrical Supply	Description	
0-21306350/16	200-230V/1Ph/50-60Hz	<b>MT6350 MO Motorised Spin Version</b> - Compact motorized truck/bus balancer, Automatic Gauge 28", AWC, automatic brake at the end of the spin; Inverter Technology System; integrated wheel lift	
0-21306352/16	100-115V/1Ph/50-60Hz	<b>MT6350 MO Motorised Spin Version</b> - as above but in different voltage	
0-21306351/16	100-230V/1Ph/50-60Hz	<b>MT6350 HS Hand Spin Version</b> - Compact handspin truck/bus balancer, Automatic Gauge 28", AWC, manual brake, integrated wheel lift	





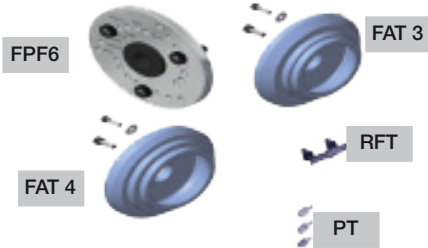

# ACCESSORIES FOR TRUCK WHEEL BALANCERS

Image	Part-no	Description	MT 6350 MO	MT 6350 HS	MT 2450	MT 2650
<b>MONITOR</b>						
	8-21100235	19" wide screen <b>monitor</b>				★
<b>CENTERING ADAPTORS</b>						
	8-21100269	<b>ART40 EVO</b> - Premium Heavy-Duty adaptor Kit (10-8-6 hole) Support flange for truck rims with central hole $\varnothing 160/176/200$ mm Support flange for truck rims with central hole $\varnothing 220/280$ mm Pcd: 6 x 205 / 6 x 222 / 6 x 245 / 8 x 275 / 8 x 285 / 10 x 335 / 10 x 285,75 / 10 x 225	★	★		
	8-21100268	<b>KCT40 EVO</b> - Heavy-Duty cone Kit Medium double sided cone, $\varnothing 159 \div 180 / 198 \div 204$ mm Large double sided cone, $\varnothing 220-281$ mm	★	★		





## ACCESSORIES FOR TRUCK WHEEL BALANCERS

Image	Part-no	Description	MT 6350 MO	MT 6350 HS	MT 2450	MT 2650
	8-21100270	<b>ARV40</b> - Premium Medium&Light commercial vehicle adaptor kit (6-hole) MERCEDES : SPRINTER VW : LT 35 / 40 / 46 FORD : TRANSIT IVECO : DAILY NISSAN : NV 400 OPEL : MOVANO 2 RENAULT : MASTER	★	★		
	8-21100261	<b>GGR40 Centering kit</b> ø 40 for central hole wheels 183,5÷223 mm - 17,5"-19,5"rims (IVECO-MAN- DAF)	★	★		
	8-21100141	<b>DX-CBF</b> Centring accessory for vans and off-road wheels Ø 117÷173 mm	★	★		
	8-21900191	<b>ARU40</b> Ø 42÷156 mm (1.65"÷6,14") - recessed spring included	★	★		
	8-21100284	<b>CBG-2</b> Alloy wheel clamping cup (Ø 220 mm). Suits GTR40 EVO quick nut	★	★		



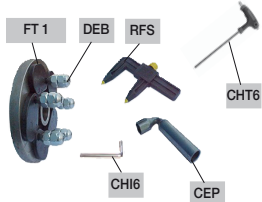

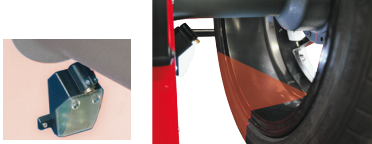
## ACCESSORIES FOR TRUCK WHEEL BALANCERS

Image	Part-no	Description		MT 6350 MO	MT 6350 HS	MT 2450	MT 2650
	8-21100275	<b>GTR40 EVO PRO</b> - Steel quick nut Ø 40x4 mm		★			
	8-21100276	<b>GTR40 EVO</b> - Quick nut Ø 40x4 mm		★			
	8-21100279	<b>GTR40 EVO HS</b> - Quick nut Ø 40x4 mm with turning handles			★		
	8-21900194	<b>GTV40</b> - Ring nut Ø 40x4 mm		★			
	8-21100272	<b>GTM40</b> - Ring nut Ø 40x4 mm			★		





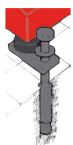
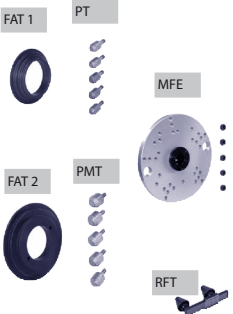

## ACCESSORIES FOR TRUCK WHEEL BALANCERS

Image	Part-no	Description		MT 6350 MO	MT 6350 HS	MT 2450	MT 2650
	8-21100091 2401415 321878 4-105877 441286 426517 600906	<b>FRU-SA D.40</b> - Universal flange for wheels with or without central hole. FT1 Connecting rod with pin DEB Conical/spheric nut for wheel fixing CHT6 T Hexagonal key CH 6 RFS Caliper CEP Hexagonal key CH 22 CHI 6 Hexagonal key CH 6		★	★		
	8-21100290	<b>TWS40</b> Truck wheel spacer Ø 40 (30mm - 1.19")		★	★		
	8-21101000	<b>AL12</b> - 12v power supply kit			★		
	8-21100238	<b>Laser &amp; Led kit</b>		★	★		
	8-21120022	<b>LASER PLANE KIT:</b> Upgrade kit to guide the operator in choosing the rim's inner planes without any errors and with extremely good visibility		★	★		
	8-21101400	<b>TRUCK TROLLEY KIT</b> for an easier handling		★	★		



## ACCESSORIES FOR TRUCK WHEEL BALANCERS

Image	Part-no	Description		MT 6350 MO	MT 6350 HS	MT 2450	MT 2650
	8-21101401	<b>ROLL-BAR KIT</b> - lateral protection		★	★		
	8-21101402	<b>ACCESSORY RACK</b>		★	★	★	★
	8-21101010	<b>KFTU Kit</b> - anchoring kit to floor		★	★		
	802239637	<b>ART</b> - Professional centring accessory for truck wheels. FAT 1 -Support flange for truck rims with hole ø160/176/200 mm FAT 2 - Support flange for truck rims with hole ø220/280 mm PT - Pin for centring truck wheels with ø18-35 mm fastener screw holes PMT - MAXI pin for centring truck wheels with ø28-47 mm fastener screw holes MFE - Hub with flange RFT - Hole detector for measuring truck wheel fastener hole distance				★	★
	802245159	<b>KCT</b> - Basic centring accessory for truck wheels 345160 DBT - Double sided truck wheel support spacer flange 345161 CT 161 - Medium double sided cone, ø159 ÷180 / 198 ÷204 mm 345162 CT 221 Large double sided cone, ø220-281 mm			★	★	

## ACCESSORIES FOR TRUCK WHEEL BALANCERS

Image	Part-no	Description		MT 6350 MO	MT 6350 HS	MT 2450	MT 2650
	802247716	<b>ARFT</b> - Centring accessory for off-road and van wheels.				★	★
	341843	DPT Van wheel support spacer flange					
	339672	CGT Large double sided cone, ø110-165 mm					
	8-21100222	<b>GGR 223</b> , Accessory for centre hole wheels from Ø 190 to 223 mm (rims Ø 17,5-19,5") IVECO - MAN - DAF				★	★
	802245527	<b>DFT</b> - Spacer for FORD F350/450 wheels for use with ARFT				★	★
	802247782	<b>ARU</b> - Basic centering accessory for car wheels				★	★
	339673	FTA Flange for reducing passenger car wheel support diameter					
	339670	CPT Small cone, ø47-64 mm					
	339671	CMT Medium double sided cone, ø60-115 mm					
	802443938	<b>GTR</b> - Quick clamping ring for truck and passenger car wheels, Ø 46				★	★
	802239121	<b>GTV</b> - Basic ring for clamping truck and passenger car wheels, Ø 46 (manual spin)				★	★

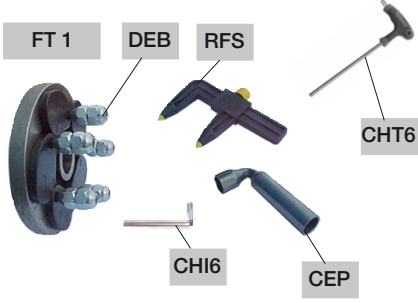
## ACCESSORIES FOR TRUCK WHEEL BALANCERS

Image	Part-no	Description		MT 6350 MO	MT 6350 HS	MT 2450	MT 2650
	8-21100256	<b>FRU-SA D.46</b> - Universal flange for car and industrial vehicle wheels 3-4-5-6 holes (without central hole). Distance between holes $\varnothing$ min. 90 max. 210 mm.				★	★
	4-135110	FT 1 Connecting rod with pin					
	4-105877	CHT6 T-Hexagonal wrench CH6					
	321878	DEB DOUBLE SIDED (conical and spherical) nut for fastening wheels					
	600906	CHI6 Hexagonal wrench CH6					
	441286	RFS Hole detector for measuring wheel fastener hole distance					
	426517	CEP Hex-headed elbow wrench CH22					
	802244344	<b>Hand spin handle</b> to be used with cod. 8-21100091		★			
<b>MISCELLANEOUS</b>							
	802461006	Adhesive <b>weight remover</b>		★	★	★	★

# AUTOMOTIVE SERVICE EQUIPMENT



[www.facebook.com/MONDOLFOFERROofficial/](http://www.facebook.com/MONDOLFOFERROofficial/)



<http://www.youtube.com/user/MondolfoFerro>

**NEXION** S.p.A.  
Viale Dell'Industria, 20 - 61037 MONDOLFO (PU) ITALY  
Tel. 0721.93671 - Telefax 0721.930232  
[info@mondolfoferro.it](mailto:info@mondolfoferro.it) - [www.mondolfoferro.it](http://www.mondolfoferro.it)

